

OPERATOR'S MANUAL

Southern Cross

SX-30 Travelling
IRRIGATOR

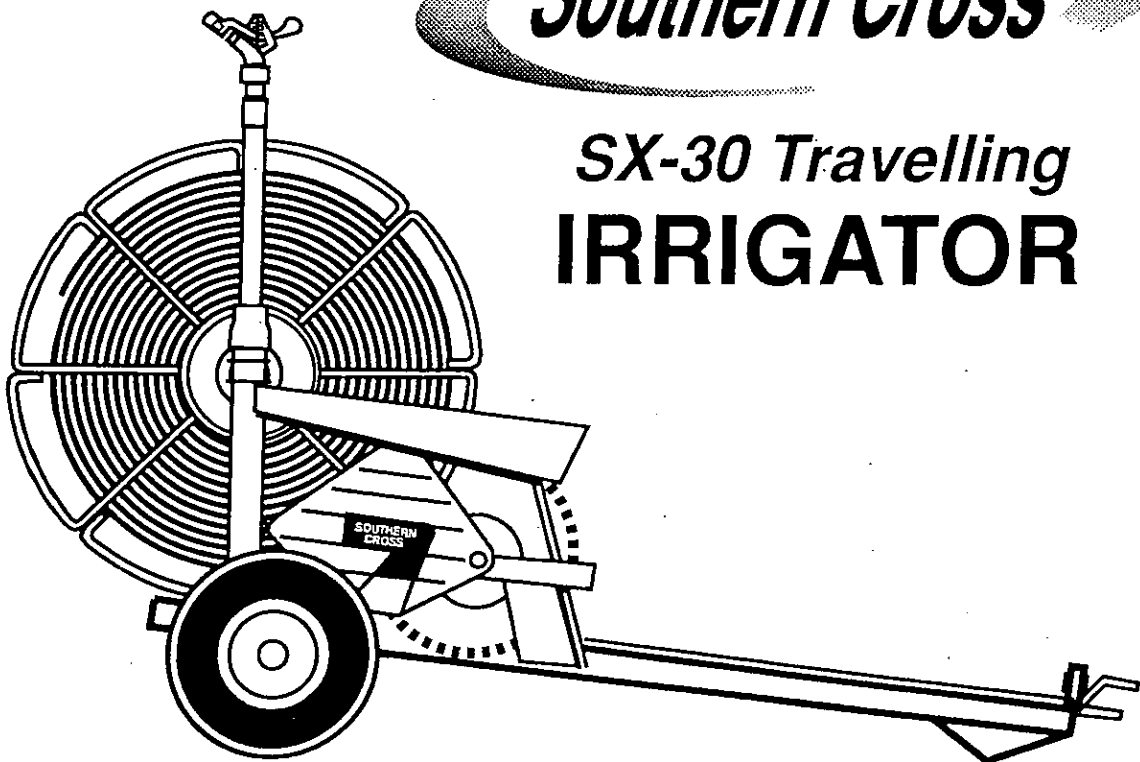

WARRANTY

SOUTHERN CROSS TRAVELLING IRRIGATORS AND HOSE REEL (EXCLUDING HOSE)

The Company warrants to the original Purchaser that it will repair or supply parts free of charge to the original point of despatch to replace parts which on return to the Company with Transport Charges prepaid shall be acknowledged by the Company to be defective in material or workmanship.

The above Warranty is subject to the following conditions:-

- (i) No claim under warranty will be acknowledged after one year from the date of delivery.
- (ii) The terms of payment contained in the contract for the supply of the goods have been complied with.
- (iii) The equipment has been installed and maintained as set out in the Instruction Manual of the Company and has been subject to normal use and service.

The foregoing Warranty is given in lieu of all other Conditions and Warranties, express or implied, which might otherwise be binding on the Company (all of which are expressly excluded) and no further responsibility for any consequential damages or any other expenses incurred will be accepted by the Company.

TOWING THE IRRIGATOR

CAUTION: Do not tow this machine faster than 25 km/h as damage to the axle, or wheel bearings may result.

TYRE PRESSURE

Maintain Tyre Pressure at 20 lbs/sq. in. (138 kPa).

INTRODUCTION

Spraying is carried out in lanes which are 2 chains wide and up to 10 chains in length. The irrigator is propelled by a hydraulic motor and moves by winding itself along a steel cable which is attached to a cable anchor, staked to the ground by an anchor post at the far end of the spraying lane. The 330 feet length of hose which connects the irrigator to the portable sub-main or hydrant is drawn along behind as the irrigator progresses.

At the end of the spraying lane, the irrigator stops automatically. After the pumping plant is closed down, the hose is rewound onto the hose reel and the irrigator is then set in position for the start of the next spraying lane.

ASSEMBLING THE IRRIGATOR

Cut wires which attach the stopping plate and bag of parts to the hose reel, and the wire which prevents hose reel from turning.

Undo the bag of parts. Remove packing tape from all openings on the irrigator. Do not remove tape from the speed control needle and spring assembly packed in the stopping plate.

(a) Speed Control Needle and Spring:

To ensure the correct assembly of the speed control needle and spring, insert the taper end of the speed control needle into the speed control valve body, situated on the exhaust water hose, alongside the standpipe. Screw in the speed control needle and remove tape from the handle and spring. Refer illustration "Adjusting Speed of Irrigator", on page 11.

(b) Pressure Gauge:

Attach the pressure gauge fittings and pressure gauge as shown in illustration "Mounting Pressure Gauge" as shown below.

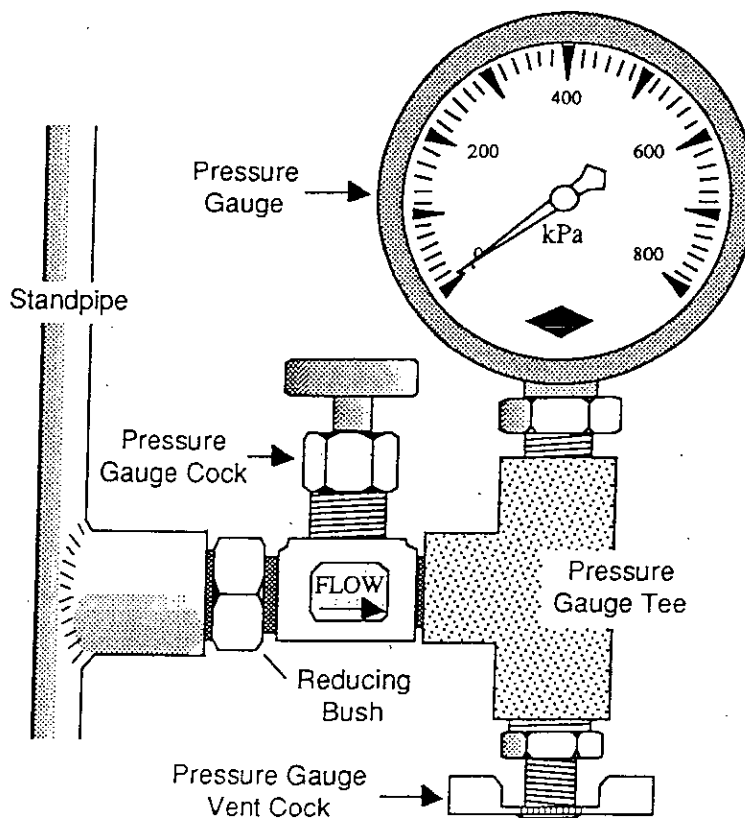

Mounting Pressure Gauge

UNPACKING THE HOSE

The hose is packed in its container in a zig-zag manner and can be pulled out without twists.

Care should be taken when unpacking to see that the hose is not damaged by tools used in the unpacking process or by surrounding objects. Remove the end of the package and pull the hose out in a straight line, ready for attaching fittings and winding it onto the hose reel.

SPRINKLER

Screw the sprinkler into the top of the standpipe and tighten it securely. Teflon tape may be used on the thread of the sprinkler but paint or other jointing compound should not be used.

LUBRICATION

Lubricate the various parts of the irrigator, using an E.P. (Extreme Pressure) grease as recommended by a reputable oil company.

Lubrication points are as follows:-

- Engine Frame Spindle or Hose Reel Spindle - 1 point
- Cable Drum Spindle - 1 point
- Rocker Arm - 3 points
- Hydraulic Motor Pivot Spindle - 1 point
- Plunger Rod to Rocker Arm Connecting Pin - 1 point
- Wheel Hubs - 2 points
- Hydraulic Motor (Plunger Rod) - 1 point
- Hose Tensioning Roller - 1 point

The various parts of the irrigator should be lubricated before operating the first time. It has been found that in irrigators as in other equipment which work under similar conditions, wear is considerably reduced by keeping working parts well lubricated. For this reason it is recommended that grease points are given some lubrication before the start of each spraying run.

ATTACHING FITTINGS TO HOSE

Onto the end of the hose fit a hose coupling, as follows:-

- a) Slide two hose clips onto the hose so that the screwdriver slots are on opposite sides of the clips. Refer illustration "Assembled Hose End", on page 5.
- b) Insert the end of the hose coupling into the hose and push the hose onto the coupling until the end of the hose comes up against the shoulder of the hose coupling.
- c) Turn the hose coupling in the hose until the latch boss of the coupling is in line with the fold of the hose.
- d) Place the two hose clips in position, behind the raised section of the hose formed by the end of the hose coupling.
- e) Turn the hose clips until the tightening screws of both clips are at the one side, and in line with the latch boss of the coupling.
- f) Tighten hose clips securely.
- g) Wind the hose onto the hose reel as shown in the following section, "Winding Hose Onto Hose Reel".
- h) Fit the remaining hose coupling to the other end of the hose as shown in paragraphs (a) to (f) above.

WINDING HOSE ONTO HOSE REEL

Turn the hose reel so that the opening in the hose reel hub is to the top. Place the hose so that it comes from the rear of the irrigator and under the hose reel hub. Push the coupling on the hose down into the opening of the hose reel hub so that the coupling points downwards, towards the rear of the irrigator. By grasping the hose reel, wind the hose onto the hose reel as shown on page 5. During the early part of the winding on operation there is sufficient drag on the hose to keep the hose packed closely on the hose reel. As the winding-on proceeds and the drag reduces, the coils become more loosely packed. When this occurs, turn the hose reel in the reverse direction to create some slack in the hose. Pass the hose down under the tensioning roller to increase the drag and proceed to wind on all of the hose. Refer illustration "Method of Winding Hose onto Hose Reel", on page 5.

STARTING COUPLINGS - (1 in. B.S.P. and 2 in. B.S.P.)

- (a) Screw the coupling onto the end of the main line, so that the slot is to the top.
- (b) Fit the sealing ring into the recess inside the coupling, so the double edges of the ring face back into the coupling.
- (c) Push the hose coupling into the starting coupling so the latch locates behind the rim of the coupling.

3 IN. PIPE MAINLINE STARTING COUPLING

The 3 in. pipe mainline starting coupling is used by one of the following methods.

- (1) Starting coupling attached to 3 in. aluminium pipe mainline.
- (2) Starting coupling attached to 3 in. outlet of hydrant outlet.
- (3) Starting coupling attached to 3 in. end of a 4 in. or 3 in. aluminium spun reducer, for attaching to 4 in. aluminium pipe mainline.
- (4) Starting coupling attached to 3 in. end of a 3 in. or 2 in. aluminium spun reducer, for attaching to 2 in. aluminium pipe

To attach the mainline starting coupling to 3 inch aluminium pipe or hydrant outlet proceed as follows:-

- (a) Wet the round 3 inch pipe sealing ring and insert it into the groove in the coupling. Refer illustration "Mainline Starting Coupling", on page 5.
- (b) Set the rolled edge of the coupling to pipe clamp plate into the sealing ring groove in the coupling and spring the plate up into position.
- (c) Push the starting coupling onto the pipe or hydrant outlet, as far as it will go so that the slot is to the top. It may be necessary to tap the coupling on lightly with a piece of wood.
- (d) Place the coupling to pipe clamp U-bolt around the pipe and the clamp plate, so the threaded ends of the U-bolt pass through the bosses on the sides of the coupling. Fit plain washers and nuts to the U-bolt and tighten nuts securely.
- (e) Fit the smaller sealing ring into the recess inside the coupling, with the double edges of the ring facing back into the coupling.
- (f) Push the hose coupling into the starting coupling so that the latch locates behind the rim on the end of the starting coupling.

NOTE: The slot in the hose coupling end of the starting coupling should be to the top. When attaching irrigation couplings to the other end of the pipe length or spun reducer, make sure that these are fitted so that the slot in the starting coupling is to the top.

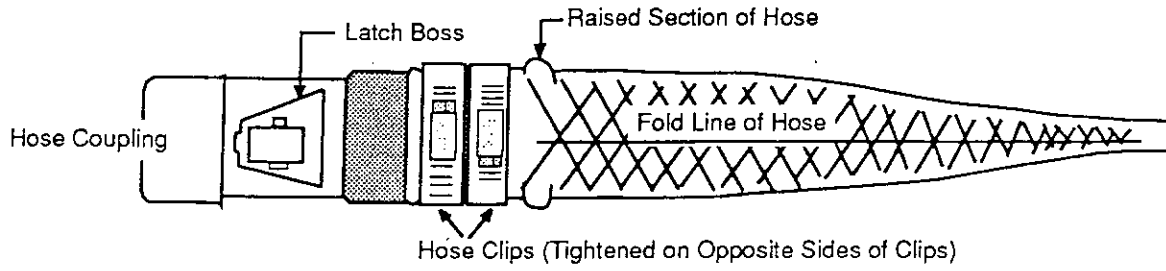

Assembled Hose End

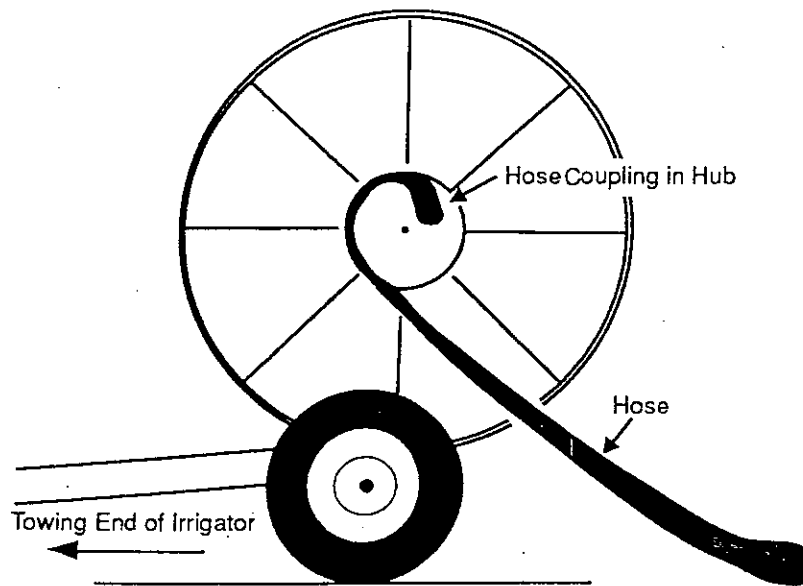

Method of Winding Hose onto Hose Reel

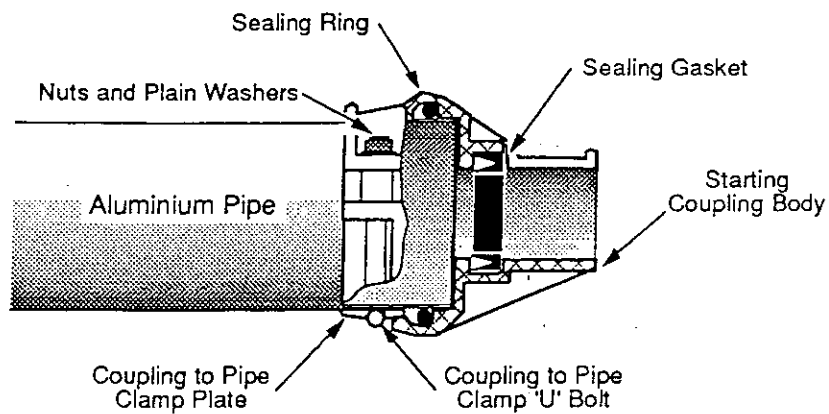

Mainline Starting Coupling

LAYING OUT THE FIELD

The area to be irrigated should be laid out in spraying lanes and suitable markers placed at the starting and finishing positions. This will assist when placing the irrigator at the start of the spraying lane and staking the cable anchor at the end of the spraying lane. The instructions show that the cable anchor is staked in position at the end of each spraying lane. If convenient, a stake can be driven in permanently at each stopping position and used as a marker for that lane.

LIMIT OF TRAVEL OF IRRIGATOR

The quantity of cable on the cable drum is in excess of that required for a spraying run. Care should therefore be taken to see that when the cable is laid out, the distance from the hydrant or fittings on the end of the portable mainline to the finishing position does not exceed the length of the hose, so that when the irrigator stops there is still some surplus hose.

MAINLINE

The mainline for supplying water to the hose of the irrigator can be a permanent installation consisting of an underground main, with hydrants. If more convenient, the mainline may consist wholly of portable lengths of mainline which are assembled as required, across the field, from the water outlet. If a portable mainline is used, a marker should be fixed in line with the water outlet, at the far side of the field. This marker will assist in laying the portable mainline in its correct position. Refer illustration "Portable Mainline", as shown below.

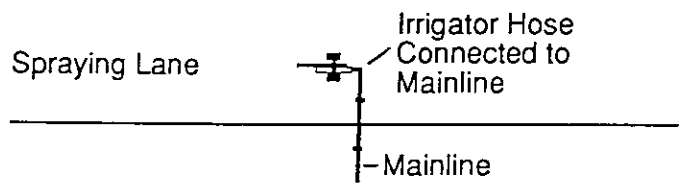
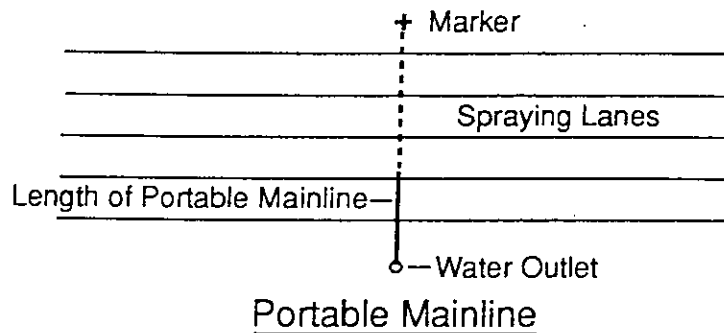

Connecting Hose to Mainline

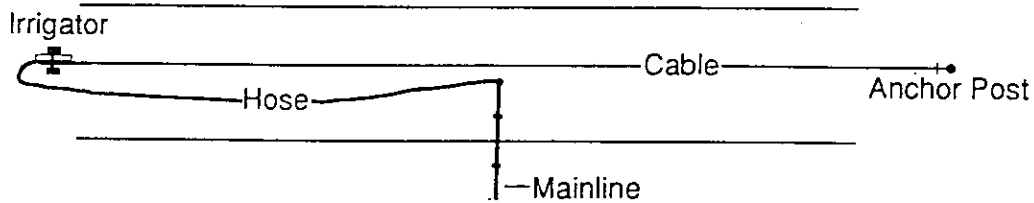

Irrigator at First Spraying Position

THE FIRST SPRAYING POSITION

The following instructions show the use of the anchor post etc., for holding the cable anchor. If a tractor is being used as an anchorage, refer section "Using Tractor as an Anchorage", on page 12.

- a) Place the irrigator at a position alongside the hydrant of the mainline or the outlet fitting on the end of the portable mainline. Attach the hose connection to the hydrant or the outlet fitting. Refer illustration "Connecting Hose to Mainline", on page 6.
- b) Wheel the irrigator along the spraying lane, up to the starting position, laying out the hose. At the starting position, turn the irrigator, so that the towing end of the irrigator is pointed towards the finishing position at the far end of the field. Refer illustration "Irrigator at First Starting Position", on page 6.
- c) Raise the canopy by lifting it at the standpipe end. Lift the driving arm (long), and prop it up, away from the ratchet section of the cable drum by fitting the angled end of the driving arm (short), into the recess in the lower side of the driving arm (long). Refer illustration "Driving Arm (long) in Raised Position", on page 9.
- d) Place the stop rod (60) in the operating position by pulling the loop at the towing end of the irrigator forward. With one hand raise the handle of the stopping lever (64) and with the other hand push the top of the stop rod trip lever (56) towards the hydraulic motor. Release the stopping lever. The stopping mechanism is now set. Refer illustration "Setting the Stopping Mechanism", on page 9. Connect hose to the irrigator and lower the canopy.
- e) The method of anchoring the cable is as shown in the illustration "Cable Anchor Attached to Anchor Post", on page 10. Carry the stopping plate and anchor post and also the end of the cable up to the other end of the field.
- f) At the far end of the field, drive the anchor post into the ground at the stopping position. Stand the anchor post in position so that the flange with the holes is pointing away from the irrigator.
- g) Fit the tubular section of the stopping plate down, over the top of the anchor post. By alternately raising the stopping plate and pulling it down sharply onto the top of the anchor post, the anchor post is driven into the ground. Refer illustration "Driving Anchor Post into Ground", on page 10.
- h) Lift the stopping plate from the anchor post and place the loop of the stopping plate so that when the stopping plate is resting on the ground, the stopping posts are vertical. Fit the cable anchor over the anchor post and allow it to slide down the anchor post. Place the cable between the stopping posts of the stopping plate. Refer illustration "Cable Anchor Attached to Anchor Post" on page 10.
- i) On established pasture or on hard soil areas, the anchor post may provide sufficient anchorage for the irrigator. Where the irrigator is being used on cultivated or loose soil areas, where tension on the cable is greatly increased, it is advisable to use a supporting stake and the anchor post link in conjunction with the anchor post. To fit the anchor post link:-
 - 1) Place the open hook end of the link through the top hole of the anchor post and hold the closed hook end out along the ground.
 - 2) At this point drive another stake at an angle, so that the flange with the holes is towards the anchor post and until one hole is at ground level. Refer illustration "Supporting the Anchor Post" on page 10.
 - 3) Unhook the anchor post link from the anchor post and fit the closed hook end through the supporting stake, at ground level.
 - 4) Place the stopping plate and cable anchor over the anchor post as shown in section (h).
 - 5) Pull the top of the anchor post towards the supporting stake and fit the open hook end through the top hole of the anchor post.
- j) Start the pumping unit. The driving arm (short), and driving arm (long), will automatically drop into position on the ratchet section of the cable drum. When operating, the hydraulic motor winches in the cable and the irrigator moves along the spraying lane. Adjust the arc of the wetted area by moving the steel circlips on the sprinkler to give the required arc of spraying. An angle of approximately 330 degrees is recommended so that the irrigator will move along on reasonably dry ground. Refer illustration "Arc of Wetted Area", on page 11. If the irrigator is operating along a fence line, spraying can be done at the one side of the irrigator by adjusting the circlips.

k) Adjust the speed of the irrigator by turning the speed control valve on the standpipe in the required direction. Refer illustration "Adjusting Speed of Irrigator", on page 11. The speed can be varied to give a travelling time of from 11 hours to 47 hours for one run of the irrigator, and applying from 1/2 in. to 4 in. of water, depending on the size of the sprinkler nozzle used. Refer table on page 18.

Notches on the side of the cable drum enable the ground speed of the irrigator to be estimated when adjusting the speed of the irrigator. Each notch on the cable drum, when viewed travelling past the edge of the driving unit represents one inch of ground travel of the irrigator.

END OF FIRST SPRAYING LANE

At the end of the spraying lane, the stopping rod engages the stopping post and the stopping mechanism operates, preventing further progress of the irrigator. The irrigator will continue to spray until the pumping unit is closed down.

TO REPOSITION THE IRRIGATOR FOR THE NEXT SPRAYING LANE

At the hydrant, or at the outlet fitting on the end of the portable machine, disconnect the hose.

Close the hydrant or, if a portable mainline is being used, add the lengths of mainline required for the next spraying lane.

Proceed to the irrigator and disconnect the hose from the inlet connection of the irrigator. Allow the hose to drain for a few minutes.

Wind the hose onto the hose reel as shown in section "Winding Hose onto Hose Reel", on page 4.

When all of the hose is on the hose reel, disconnect the cable anchor from the anchor post and withdraw the post. Carry the anchor post, and stopping plate to the next stopping position, and stake the stopping plate to the ground.

At the irrigator, prop the driving arm (long) up, away from the cable drum ratchet, by means of the driving arm (short). Wind surplus cable onto the cable drum, by hand. If necessary release the cable drum brake to reduce drag on the cable drum when winding on surplus cable, but re-adjust the brake when the cable has been wound on. Refer section "Cable Drum Brake", below.

Wheel the irrigator along the end of the field and up to the next hydrant or the end of the portable mainline. Connect the hose to the hydrant or outlet fitting on the portable mainline and proceed to position the irrigator, hose and cable as shown in the section, "The First Spraying Position", on page 7. Lubricate the irrigator, as shown in section, "Lubrication" on page 3.

CABLE DRUM BRAKE

At the Factory, the cable drum brake is adjusted to the generally used setting. This setting can be adjusted, if required, to either increase or decrease the braking effect of the brake on the cable drum.

To adjust the cable drum brake:-

(a) Loosen the locknut on the cable drum brake adjusting screw.

(b) To increase drag on the cable drum, screw the adjusting screw inwards. To decrease the drag, screw the adjusting screw outwards.

(c) Re-tighten the locknut on the cable drum brake adjusting screw.

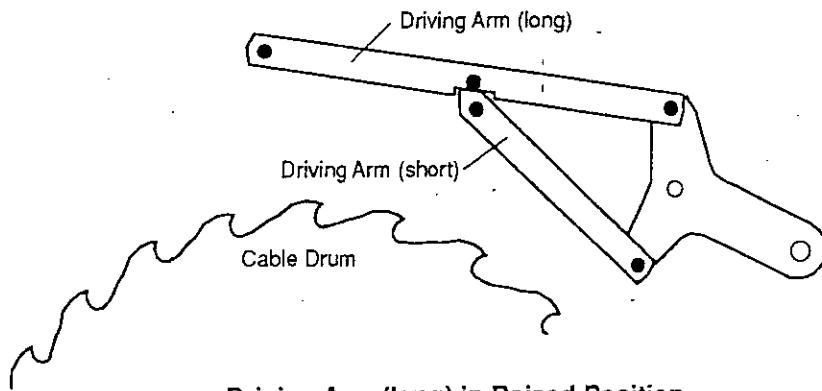

Driving Arm (long) in Raised Position

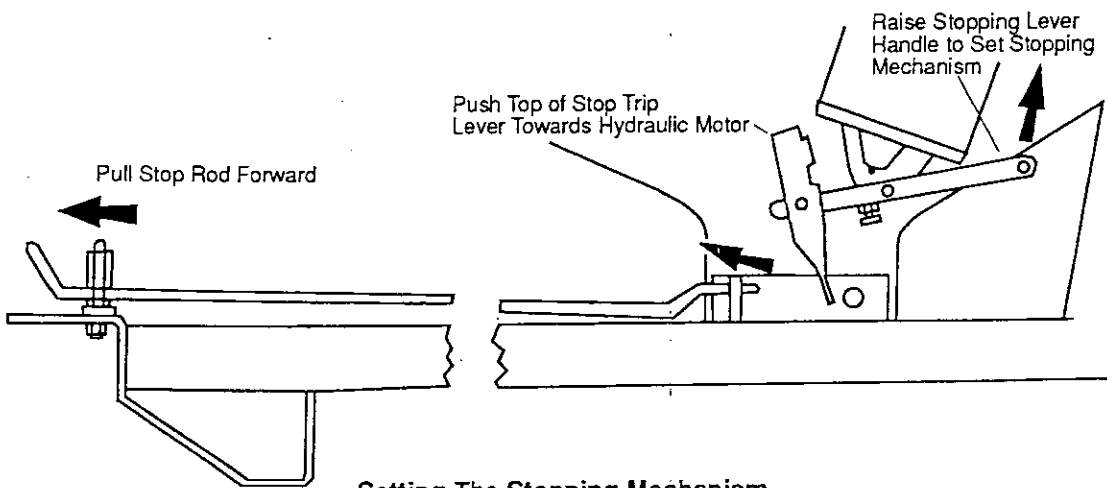

Setting The Stopping Mechanism

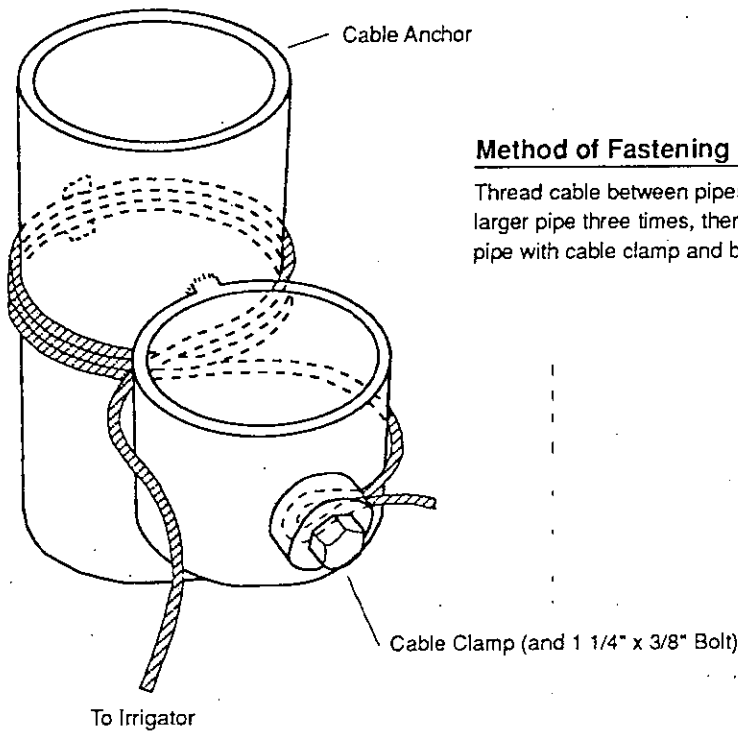

Method of Fastening Cable to Cable Anchor

Thread cable between pipes so that cable winds round larger pipe three times, then fasten cable end to small pipe with cable clamp and bolt.

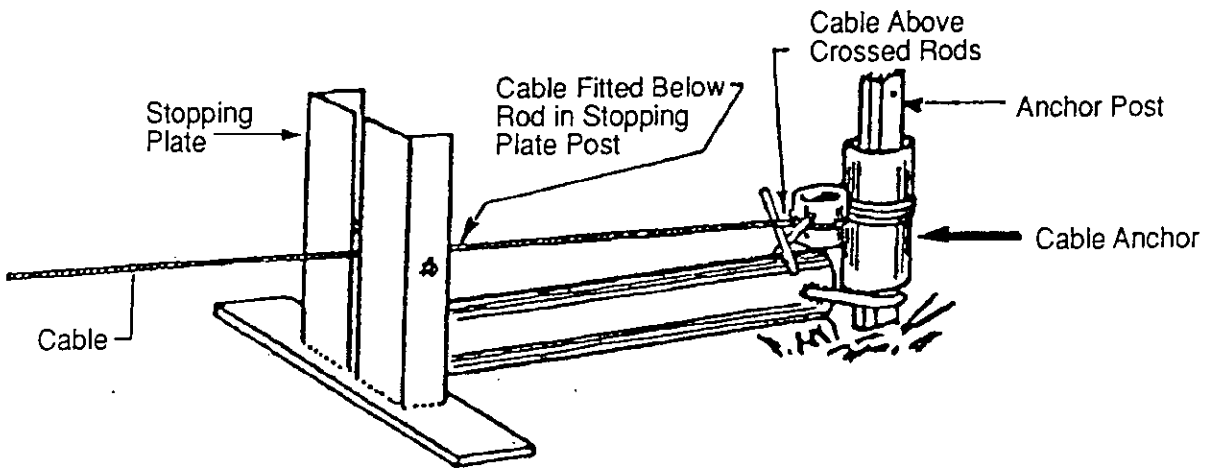

Cable Anchor Attached to Anchor Post

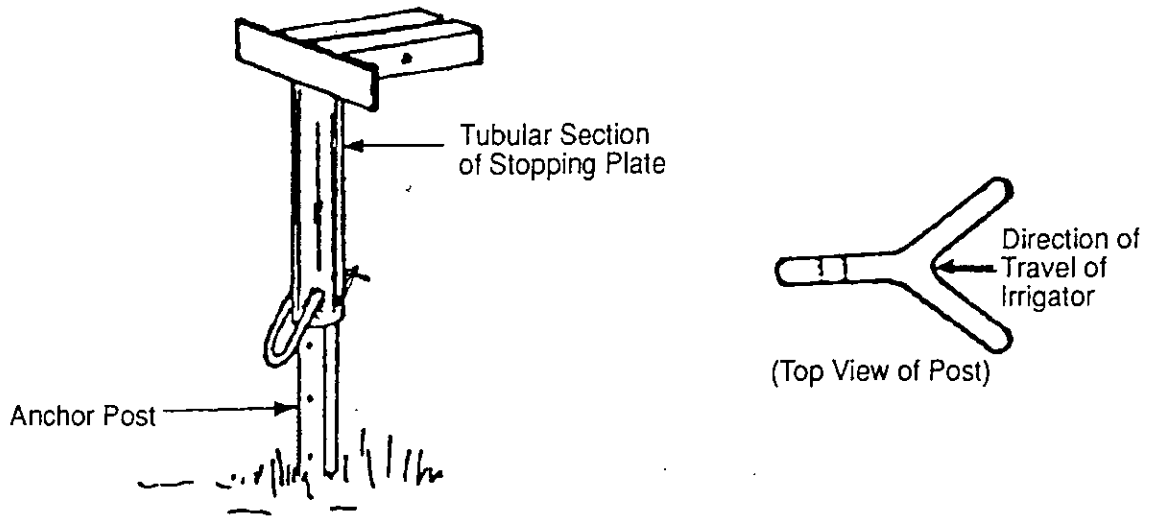

Driving Anchor Post into Ground

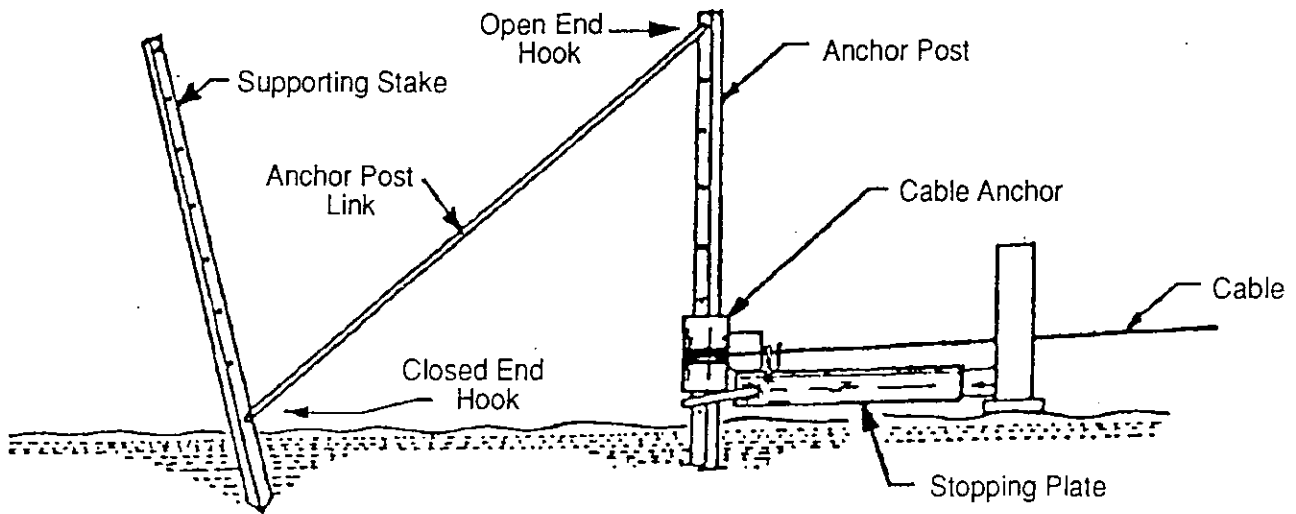

Supporting the Anchor Post

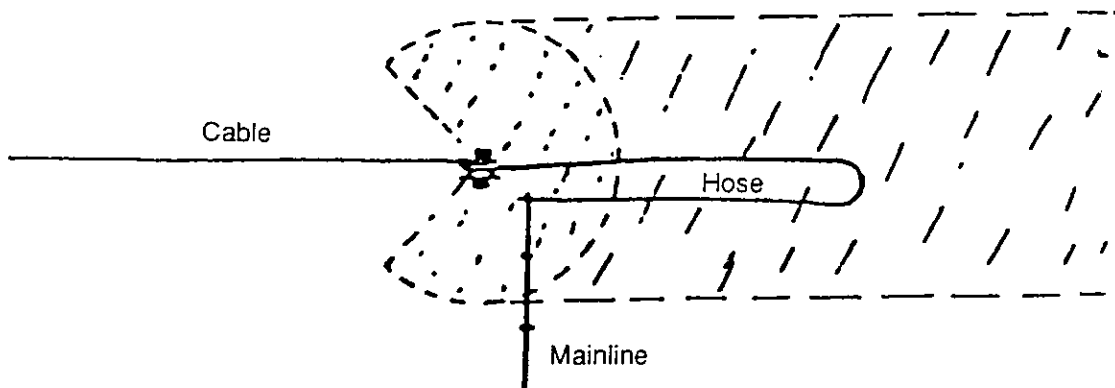

Arc of Wetted Area

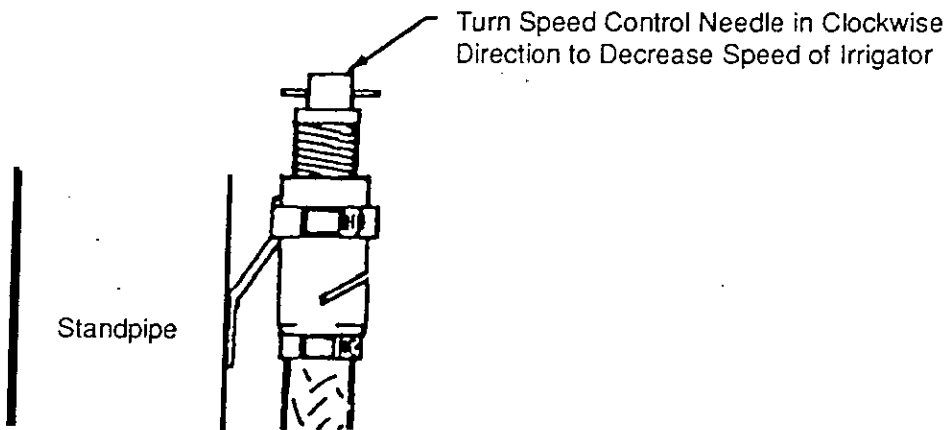

Adjusting Speed of Irrigator

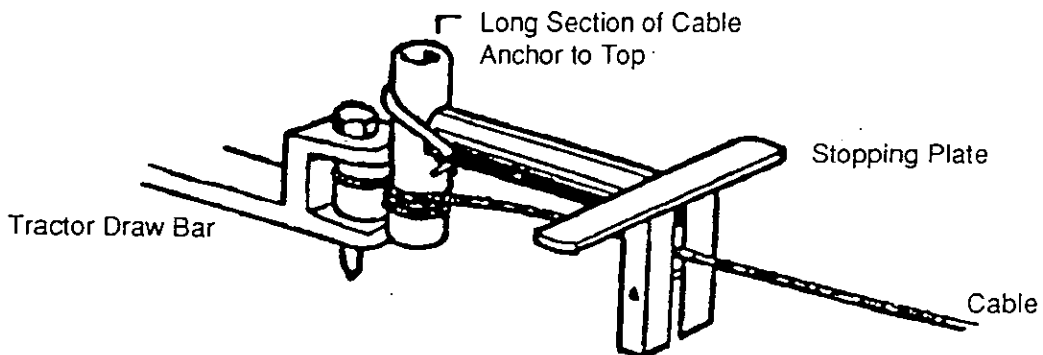

Attaching Cable Anchor to Tractor

WINTER OPERATION OF IRRIGATOR

If the irrigator is being used in winter, in areas where freezing conditions can be expected, it is advisable to time the spraying run so that the irrigator operates throughout the night and does not stand idle. Water will not freeze in the irrigator while it is operating, thus preventing damage to the hydraulic motor should freezing conditions occur. If the irrigator is to stand idle during freezing conditions, clear water from the hydraulic motor, as follows:-

- (a) Adjust the speed control to the fastest speed setting.
- (b) Hold the rocker arm at the end which is connected to the plunger rod and operate the plunger rod, up and down for a few strokes to force water from the motor.

OFF-SEASON STORAGE OF IRRIGATOR

When the irrigator is not to be used for some time, it is advisable to store it under shelter and remove as much water as possible from the hydraulic motor, as shown in section "Winter Operating of Irrigator", above. Besides possible damage from water in the hydraulic motor freezing in cold conditions, the corrosive action of some waters may cause damage to certain internal parts of the irrigator.

CARE OF CABLE AND HOSE

The life of the cable and hose will be increased if they are always handled with care. Twisting, looping and snagging should be avoided. When it is not in use, the hose should not be left lying in the field where it could be damaged by tractors or implements, but reeled onto the hose reel and stored under cover.

USING TRACTOR AS AN ANCHORAGE

If a tractor is being used as an anchorage for the cable, attach the cable and stopping plate as follows:-

- (a) Hold the short tubular section of the cable anchor between the ends of the tractor draw bar, so the longer end of the remaining tube is to the top. Refer illustration "Attaching Cable Anchor to Tractor" on page 11.
- (b) Fit the draw bar pin down, through the tractor draw bar and the cable anchor.
- (c) Turn the stopping plate, so the stopping posts are directed towards the ground and fit the loop of the stopping plate over the top of the cable anchor.
- (d) Arrange the cable so that it is situated between the stopping posts of the stopping plate, and above the horizontal rod on the stopping plate post.

To Take a Pressure Reading:

- (i) Make sure the pressure gauge vent cock is closed.
- (ii) Open Pressure Gauge Cock and observe pressure gauge reading. Close Pressure Gauge Cock.
- (iii) Open Pressure Gauge Vent Cock to release pressure in pressure gauge.
- (iv) Close Pressure Gauge Vent Cock.

NOTE: At the change-over of the stroke of the motor, a sudden pulse is transmitted through water in the standpipe. This continual pulsing can cause early failure of the pressure gauge if the gauge is not isolated. The pressure gauge should be exposed to pressure only while a pressure reading is being taken, and then, for the shortest period required.

MAINTENANCE

To Clean The Filter

The filter used for filtering water for the hydraulic motor is of a self-cleaning design, but when used with some waters, the filter may eventually become choked.

The effect of a choked filter is the reduction in the stroking rate and consequent slowing down of the irrigator. When this occurs, stop the pumping unit and clean the filter, as follows:-

- (a) Disconnect the hose from the irrigator.
- (b) Remove the female hose connection sealing ring (11) from the groove inside the filter body.
- (c) Lift the filter from the filter body..
- (d) Clean the filter, outside and inside, using a stiff bristle brush, and flushing the filter in clean water, several times, between brushings.
- (e) When the filter is clean, refit it and the rubber sealing ring (11) in the filter body. Make sure that the double edges of the V-section of the sealing gasket face back, into the filter body.
- (f) Reconnect the hose to the irrigator and restart the pumping unit.

To Repair a Damaged Hose

When it is necessary to repair a damaged hose, cut out the damaged section and fit a hose joiner, as follows:-

- (a) Cut ends of the hose where it is to be joined so that they are square.
- (b) Onto each hose end fit a pair of hose joiner clips, so that the screw drive slots of the clips in each pair are on opposite sides of the clips.
- (c) Push the ends of the hose onto the hose joiner right up to the shoulder.
- (d) At each end of the hose joiner, fit the two hose joiner clips, over the hose, behind the ridge formed by the rim on the end of the hose joiner. When fitted the screws of all the clips should be in line with the fold of the hose. Tighten all clips securely.

TO REMOVE AND DISMANTLE THE HYDRAULIC MOTOR

It will be necessary to dismantle the hydraulic motor to carry out any of the following maintenance operations:-

- (a) Renew pilot valve valve seals.
- (b) Renew spool valve seals.
- (c) Replace hydraulic motor buckets.
- (d) Fit new plunger rod seal.

To Remove Hydraulic Motor From Irrigator

The hydraulic motor can be removed from the irrigator with hose wound onto the hose reel, but it is much more convenient to carry out this work while the hose reel is empty.

- (1) Raise the canopy (186).
- (2) Loosen clips (Z) which attach foliage guard to the chassis.

(3) Unscrew the foliage guard retaining setscrew (175), situated in the end of the cable drum spindle (102) and slide the driving unit brace spacer (171) from between the driving unit brace of the foliage guard and the end of the cable drum spindle.

(4) Remove nut and spring washer from the bolt which attaches the driving unit brace of this foliage guard to the chassis, along-side the hydraulic motor, and slide the bolt back to release the foliage guard.

(5) Slide the foliage guard along the horizontal section of the chassis to allow free access to the motor.

(6) Loosen hose clips (E & F) on hoses where they connect to the inlet and exhaust connections of the hydraulic motor.

(7) Push the plunger rod (78) down as far as it will go. Hold the pilot valve control arm (82) and remove the plunger rod nut (79) from the top of the plunger rod (78). Raise the driving arms (73 & 74) and turn the rocker arm (71) to release it from the plunger rod.

(8) Release the stopping lever spring (59) from the stopping lever spring mount (58).

(9) Unscrew the "Nyloc" nut from the stud situated in the end of the hydraulic motor pivot pin (85), at the bottom of the hydraulic motor. Remove the plain washer and slide the stopping lever (64) from the stud.

(10) Using a pair of circlip pliers, remove the circlip (C) from the hydraulic motor pivot pin (85) and slide off the washer.

(11) Lock two nuts together on the stud from which the stopping lever was removed and screw out the stud.

(12) Pull the hydraulic motor sideways to remove it from the hydraulic motor pivot pin.

NOTE: Rocker arm spindle washers and hydraulic motor pivot spindle washers are supplied in two thicknesses and must be refitted in their original positions when the irrigator is being re-assembled.

To Dismantle the Hydraulic Motor

NOTE: Before dismantling the hydraulic motor, note the position of the pilot valve control arm slide (200 & 201) and the stopping lever spring mount (58), so that these parts will be attached correctly when the hydraulic motor is reassembled. Do not separate parts of the pilot valve control arm slide assembly as they have been correctly adjusted at the Factory.

Dismantle the hydraulic motor as follows:-

(1) Lay the motor on a bench so that the plunger rod (78) is horizontal.

(2) Remove setscrews which attach the end caps (88 & 89) to the hydraulic motor body (90) and remove the end caps. Do not lose the aluminium washers.

Components of Pilot Valve and Spool Valve Chambers

During dismantling and re-assembly of the hydraulic motor, the various components of the pilot valve chamber and the spool valve chamber should be kept separate, and in order so that they can be refitted in their correct positions.

To Fit New Rubber Seals

(1) The valve seals (383) and rings (108) used in the pilot valve and main spool valve chambers are the same. The remaining parts, the inner spacers and outer spacers, are different. For this reason, these parts must be refitted in their correct positions when reassembling. It is recommended that when new valve seals are being fitted to an irrigator, dismantling and reassembly of one chamber is completed before parts in the remaining chamber are withdrawn and reassembled.

(2) Do not re-use rubber valve seals removed from the pilot valve or main spool valve chambers. The outer lips of the seals will have been damaged by the removal process.

(3) Keep all parts wet with water during reassembly.

(4) Do not push rubber valve seals straight into the valve chambers, as the edges of the seals may be damaged where they travel across the ports (holes). Always introduce the seals at an angle and straighten them up into position, so that wherever possible, the edges do not have to travel across ports.

To Dismantle Pilot Valve or Main Spool Valve

(a) A removal tool is recommended for removing lantern rings and rubber seals.

(b) Slide the main spool valve from the hydraulic motor body. The pilot valve would have been removed when the end caps were removed.

(c) Remove the bronze outer spacers from each end of the valve chamber.

(d) Insert the end of the removal tool into the inside of the valve seal and work the angled end down between the seal and the lantern ring. Withdraw the rubber seal. Repeat this procedure at the other side of the valve chamber.

(e) Insert the removal tool between the lantern ring and the next valve seal, from the inside of the lantern ring and pull out the lantern ring.

(f) Continue as in (d) and (e) above until all rubber valve seals and lantern rings are removed. Slide out the valve spacer (inner).

To Reassemble the Pilot Valve or Main Spool Valve

(a) Wet the inside of the valve chamber and insert the valve spacer (inner). Push the spacer to approximately the middle position of the chamber.

(b) Dip one of the rubber valve seals in water and insert it at an angle into the chamber so that one edge of the valve seal touches the valve spacer (inner).

(c) Push the seal up into position, along-side the spacer. Care must be taken to see that wherever possible the edge of the valve seal is not pushed across a port, otherwise the outer edge of the seal may be damaged.

(d) Repeat this procedure at the other side of the chamber.

(e) Insert a lantern ring into each end of the chamber and push these into position alongside the valve seals.

(f) At each side of the chamber, insert a rubber valve seal and push them up into position alongside the lantern rings, as before.

(g) Insert another lantern ring and rubber seal into each end of the chamber and push these into position, as already shown.

(h) Fit the bronze outer spacers into the chamber.

(i) Wet the main spool valve and insert it into the valve chamber.

(j) Examine the plunger rod seal (206) and if it is worn or damaged, replace it with a new one.

To fit a new plunger rod seal:-

(1) Lift the plunger rod seal from its seat in the hydraulic motor top end cap, using the blade of a screwdriver or a pair of long nosed pliers.

(2) Dip the new seal in water and insert it, smaller end first into its seating.

TO REASSEMBLE THE IRRIGATOR

Reassemble the hydraulic motor by reversing the dismantling procedure, paying particular attention to the following:-

Pilot Valve Control Arm

When refitting the pilot valve control arm, fit a pilot valve control arm bush (76) to the bolt and fit the bolt through the pilot valve control arm (82) and the plunger rod (78). Onto the bolt fit a bush, spring washer and the nut. Do not over-tighten the bolt.

Plunger Rod Nut

After the hydraulic motor has been installed in the irrigator, when tightening the plunger rod nut, hold the edge of the pilot valve control arm (82) just clear of the pilot valve control arm slide (200) so that when the nut is tightened, the control arm is still free to move up and down, without binding on the slide.

To Check Pilot Valve Setting

The pilot valve must be correctly set, otherwise damage to parts of the hydraulic motor may result. If the instructions for fitting plunger buckets have been followed and the positioning of the plunger on the plunger rod has been carefully carried out, as shown, the pilot valve setting should be correct. However, after the hydraulic motor has been dismantled and reassembled, the pilot valve setting should be checked and adjusted if necessary, before using the irrigator.

Check the pilot valve setting as follows:-

- (a) Push the plunger rod (78) down into the hydraulic motor, as far as it will go.
- (b) Push the pilot valve control rod (81) down as far as it will go.
- (c) Check that there is approximately 1/16 inch total free movement up and down between the lower face of the pilot valve control arm (82) and the pilot valve nut directly below. If the clearance is not correct, loosen the locknuts each side of the pilot valve rod coupling (380) and adjust the coupling and nuts. Retighten the locknuts.
- (d) Recheck the setting to make sure that it is correct.
- (e) Pull the plunger rod up, as far as it will go.
- (f) Pull the pilot valve control rod up, to its uppermost limit.
- (g) Check that clearance between the lower face of the pilot valve nut and the top face of the pilot valve control arm (82) is approximately 1/16 inch. If it is not, unlock the locknuts on the end of the pilot valve control rod (81) and adjust the nuts until clearance is correct.
- (h) Retighten the locknuts and recheck this setting.

Pilot Valve Control Arm Adjusting Nuts

If the hydraulic motor is ever totally dismantled, care should be taken to ensure that the pilot valve control arm adjusting nuts (136) and locknuts are refitted in their correct positions. The pilot valve control arm adjusting nuts, which have a larger size hexagon than the locknuts, must be situated so that, when the hydraulic motor is operating, these adjusting nuts contact the pilot valve control arm (82).

Spool Valve

If the irrigator does not start, particularly after the irrigator has been in storage, it is possible that the spool valve is being held by the spool valve seals. To free the spool valve, unscrew the plug in the hydraulic motor top end cap and insert a piece of bar or screwdriver and push down on the spool valve. Refit plug. Wooden dowel or a stick should not be used as splinters of wood could remain in the valve mechanism.

SX - 30 IRRIGATOR - TROUBLE SHOOTING CHART

SYMPTOM	CAUSE	REMEDY
(a) Failure of Motor to start.	<ol style="list-style-type: none"> 1. Stopping Lever not set. 2. Speed Control Valve Screwed right in. 3. Spool Valve stuck due to:- <ol style="list-style-type: none"> (a) Sand and Grit in Motor. (b) Defective Spool Valve (c) Defective Sealing Rings (d) Stopping Plunger stuck 4. Motor has previously been frozen. (Symptom (d) will also be in evidence in this case). 	<ol style="list-style-type: none"> 1. Set Stopping Lever. 2. Set Speed Control Valve. 3. (a) Dismantle motor and clean (Check Filter for Fractures) (b) Fit new Spool Valve (c) Replace Sealing Rings for Pilot Valve (d) Remove Bottom Cap and free Plunger. 4. As for Symptom (d), Remedy 2.
(b) Motor stopping	<ol style="list-style-type: none"> 1. Spool Valve sticking due to:- <ol style="list-style-type: none"> (a) Sand and Grit in Motor. (b) Defective Spool Valve. (c) Defective Sealing Rings. 2. Motor has previously been frozen. (Symptom (d) will also be in evidence in this case). 	<ol style="list-style-type: none"> 1. (a) Dismantle motor and clean (b) Fit new Spool Valve. (c) Replace Sealing Rings for Pilot Valve. 2. As for Symptom (d), Remedy 2.
(c) Water leaking around Pilot Valve Stem.	<ol style="list-style-type: none"> 1. Pilot Valve Sealing Rings defective. 2. Pilot Valve Control Arm rubbing on Pilot Valve Control Rod. 	<ol style="list-style-type: none"> 1. Replace Pilot Valve Sealing Rings. 2. Loosen Plunger Rod Nut, centralize Pilot Valve Control Arm on Pilot Valve Control Rod and retighten nut.
(d) Water leaking from small 5/64" dia. Vent Holes in Water Motor Body.	<ol style="list-style-type: none"> 1. Defective Sealing Rings. 2. Buckled Top and/or Bottom Cap due to Water Motor having been frozen. 	<ol style="list-style-type: none"> 1. Replace Sealing Rings for Pilot Valve and Spool Valve Spacer Sealing Rings. 2. Remove Top and Bottom Caps and check Sealing Faces for flatness with a straight edge. Replace buckled cap
(e) Failure of Driving Arm Pins to engage in Cable Drum Teeth particularly under heavy load.	<ol style="list-style-type: none"> 1. Bent Driving Arm Clamp Bolts. 2. Plunger Rod Bucket Retaining Nut has become loose. 3. Incorrect setting of bucket. dimension of 6-1/32 in. as per Instruction Manual. 	<ol style="list-style-type: none"> 1. Dismantle Driving Arms and check bolts. Replace if bent. Tighten bolts securely. 2. Tighten Plunger Rod Bucket Retaining Nut. 3. This Dimension is set at the Factory, however if motor has been dismantled this dimension could have altered. To remedy, dismantle motor and reset bucket dimension to 6-1/32 in. <p>NOTE: Pilot Valve Adjusting Nuts should <u>not</u> be altered in an endeavour to cure this problem. Providing the Pilot Valve Setting is correct as per the Instruction Book.</p>

Performance Table

Sprinkler & Hose	Nozzle Dia mm (inch)	Pressure at Sprinkler kPa (psi)	Flow Rate L/sec (gpm)	Sprinkler Wetted Width m (ft)	Area Irrigated in 200m (560ft) Run ha (acres)	Average Application Rate per Hour (Full Circle) mm (points)	Depth of Water Applied Per Irrigation mm (inches)			Friction Loss in Hose, etc kPa (psi)		Lane Spacing m (feet)	
							11 Hr. Run	23 Hr. Run	47 Hr. Run	1 1/2" Hose	2" Hose		
Rainbird 85-EW Sprinkler - 44 or 50mm (1 3/4 or 2 inch) Hose 100m Long	15.9 (5/8)	413 (60)	5.1 (67.3)	61.6 (202)	0.87 (2.14)	7.2 (28.3)	23 (0.92)	49 (1.92)	100 (3.93)	158.6 (23.0)	82.7 (12.0)	43.0 (141)	
		482 (70)	5.5 (73.1)	63.4 (208)	0.89 (2.20)		25 (0.97)	52 (2.03)	105 (4.15)	186.2 (27.0)	96.5 (14.0)	44.2 (145)	
		551 (80)	5.9 (78.4)	65.2 (214)	0.92 (2.28)		26 (1.01)	53 (2.10)	109 (4.30)	220.6 (32.0)	113.8 (16.5)	45.8 (150)	
	14.3 (9/16)	413 (60)	4.2 (55.4)	59.4 (195)	0.84 (2.08)	0.84 (2.08)	6.4 (25.0)	20 (0.78)	41 (1.63)	85 (3.33)	106.9 (15.5)	55.2 (8.0)	41.8 (137)
		482 (70)	4.6 (60.2)	61.6 (202)	0.87 (2.14)	0.87 (2.14)		21 (0.82)	44 (1.72)	89 (3.52)	127.6 (18.5)	65.5 (9.5)	43.0 (141)
		551 (80)	4.9 (64.6)	63.4 (208)	0.89 (2.21)	0.89 (2.21)		22 (0.85)	45 (1.78)	92 (3.64)	144.8 (21.0)	75.8 (11.0)	44.5 (146)
	13.5 (17/32)	413 (60)	3.7 (48.0)	57.6 (189)	0.81 (2.00)	0.81 (2.00)	5.8 (23.0)	18 (0.72)	38 (1.50)	78 (3.06)	92.7 (12.0)	42.7 (6.2)	40.3 (132)
		482 (70)	4.0 (52.9)	59.8 (196)	0.84 (2.08)	0.84 (2.08)		19 (0.74)	40 (1.56)	81 (3.18)	96.5 (14.0)	45.5 (6.6)	41.8 (137)
		551 (80)	4.3 (56.8)	61.6 (202)	0.87 (2.14)	0.87 (2.14)		20 (0.78)	41 (1.62)	84 (3.32)	110.3 (16.0)	59.3 (8.6)	43.0 (141)
	12.7 (1/2)	413 (60)	3.3 (44.2)	55.5 (182)	0.78 (1.92)	0.78 (1.92)	5.7 (22.5)	17 (0.67)	36 (1.40)	73 (2.87)	67.6 (9.8)	35.2 (5.1)	38.7 (127)
		482 (70)	3.6 (47.9)	57.6 (189)	0.81 (2.00)	0.81 (2.00)		18 (0.70)	37 (1.46)	76 (2.99)	79.3 (11.5)	39.3 (5.7)	40.3 (132)
		551 (80)	3.9 (51.3)	59.4 (195)	0.84 (2.08)	0.84 (2.08)		18 (0.72)	38 (1.51)	78 (3.08)	91.0 (13.2)	46.9 (6.8)	41.8 (137)
11.9 (15/32)	413 (60)	3.0 (39.5)	54.0 (177)	0.76 (1.88)	0.76 (1.88)	5.5 (21.5)	15 (0.61)	33 (1.28)	67 (2.62)	53.8 (7.8)	27.6 (4.0)	37.8 (124)	
	482 (70)	3.2 (42.8)	55.8 (183)	0.79 (1.94)	0.79 (1.94)		16 (0.64)	34 (1.35)	70 (2.75)	62.1 (9.0)	32.4 (4.7)	39.0 (128)	
	551 (80)	3.5 (45.9)	57.6 (189)	0.81 (2.00)	0.81 (2.00)		17 (0.67)	36 (1.40)	73 (2.86)	72.4 (10.5)	37.9 (5.5)	40.3 (132)	
11.1 (7/16)	413 (60)	2.6 (34.7)	52.4 (172)	0.74 (1.82)	0.74 (1.82)	5.1 (20.0)	14 (0.56)	30 (1.17)	60 (2.38)	41.4 (6.0)	21.4 (3.1)	36.6 (120)	
	482 (70)	2.8 (37.6)	54.3 (178)	0.77 (1.89)	0.77 (1.89)		15 (0.58)	31 (1.21)	63 (2.48)	48.3 (7.0)	24.1 (3.5)	38.1 (125)	
	551 (80)	3.1 (40.3)	56.1 (184)	0.79 (1.95)	0.79 (1.95)		15 (0.60)	32 (1.26)	65 (2.57)	55.2 (8.0)	28.3 (4.1)	39.3 (129)	
10.3 (13/32)	413 (60)	2.3 (29.9)	50.6 (166)	0.71 (1.76)	0.71 (1.76)	4.7 (18.5)	13 (0.50)	28 (1.04)	54 (2.12)	30.3 (4.4)	15.2 (2.2)	35.4 (116)	
	482 (70)	2.5 (32.4)	52.4 (172)	0.74 (1.82)	0.74 (1.82)		13 (0.52)	28 (1.09)	56 (2.22)	36.5 (5.3)	18.6 (2.7)	36.6 (120)	
	551 (80)	2.6 (34.8)	54.3 (178)	0.77 (1.89)	0.77 (1.89)		14 (0.54)	28 (1.12)	58 (2.29)	41.4 (6.0)	21.4 (3.1)	38.1 (125)	
9.5 (3/8)	413 (60)	1.9 (25.7)	48.5 (159)	0.68 (1.68)	0.68 (1.68)	4.3 (17.0)	11 (0.45)	24 (0.93)	49 (1.91)	22.8 (3.3)	8.3 (1.2)	33.9 (111)	
	482 (70)	2.1 (27.8)	50.6 (166)	0.71 (1.76)	0.71 (1.76)		12 (0.46)	25 (0.97)	50 (1.97)	26.2 (3.8)	13.1 (1.9)	35.4 (116)	
	551 (80)	2.3 (29.8)	52.4 (172)	0.74 (1.82)	0.74 (1.82)		12 (0.48)	25 (1.00)	52 (2.05)	30.3 (4.4)	15.2 (2.2)	36.6 (120)	
8.7 (11/32)	413 (60)	1.6 (21.5)	47.3 (155)	0.67 (1.65)	0.67 (1.65)	3.8 (15.0)	10 (0.38)	20 (0.79)	41 (1.62)	15.9 (2.3)	8.3 (1.2)	33.2 (109)	
	482 (70)	1.8 (23.4)	49.4 (162)	0.69 (1.71)	0.69 (1.71)		10 (0.40)	21 (0.83)	43 (1.71)	19.3 (2.8)	9.7 (1.4)	34.5 (113)	
	551 (80)	1.9 (25.3)	50.9 (167)	0.72 (1.77)	0.72 (1.77)		11 (0.42)	22 (0.87)	45 (1.78)	22.1 (3.2)	11.0 (1.6)	35.7 (117)	
		620 (90)	2.1 (27.3)	52.7 (173)	0.74 (1.83)		11 (0.43)	23 (0.91)	47 (1.86)	25.5 (3.7)	13.1 (1.9)	36.9 (121)	

1 2 3 4 5 6 7 8 9 10 11 12 13 14 15 16 17 18 19 20 21 22 23 24 25 26 27 28 29 30 31 32 33 34 35 36 37 38 39 40 41 42 43 44 45 46 47 48 49 50 51 52 53 54 55 56 57 58 59 60 61 62 63 64 65 66 67 68 69 70 71 72 73 74 75 76 77 78 79 80 81 82 83 84 85 86 87 88 89 90 91 92 93 94 95 96 97 98 99 100

This is the rate of travel of the irrigator

NOTES

- Col 1. When calculating head include height of sprinkler above ground - 153cm (5 ft).
- Col 2. The figures shown in this column are those discharged by the sprinkler. The travelling mechanism also uses water at the following rates which must be added: 0.11 L/sec (1.4 G.P.M.) for 11 hour run; 0.05 L/sec (0.7 G.P.M.) for 23 hour run; 0.02 L/sec (0.3 G.P.M.) for 47 hour run.
- Col 3. Includes friction loss in irrigator, hose and fittings.
- Col 4. Lane spacing is for 0.8 k.p.h. (0.5 m.p.h.) winds based on 70% of wetted width. For winds of 8-16 k.p.h. (5-10 m.p.h.) use lane spacing of 60 % of wetted width. For winds over 16 k.p.h. (10 m.p.h.) use lane spacing of 50% of wetted width.
- Col 5. Application rate is for full circle operation in calm conditions. Part circle increases application rate, eg. for 330 degree arc of rotation (which is recommended) multiply by 1.09 (12/11).

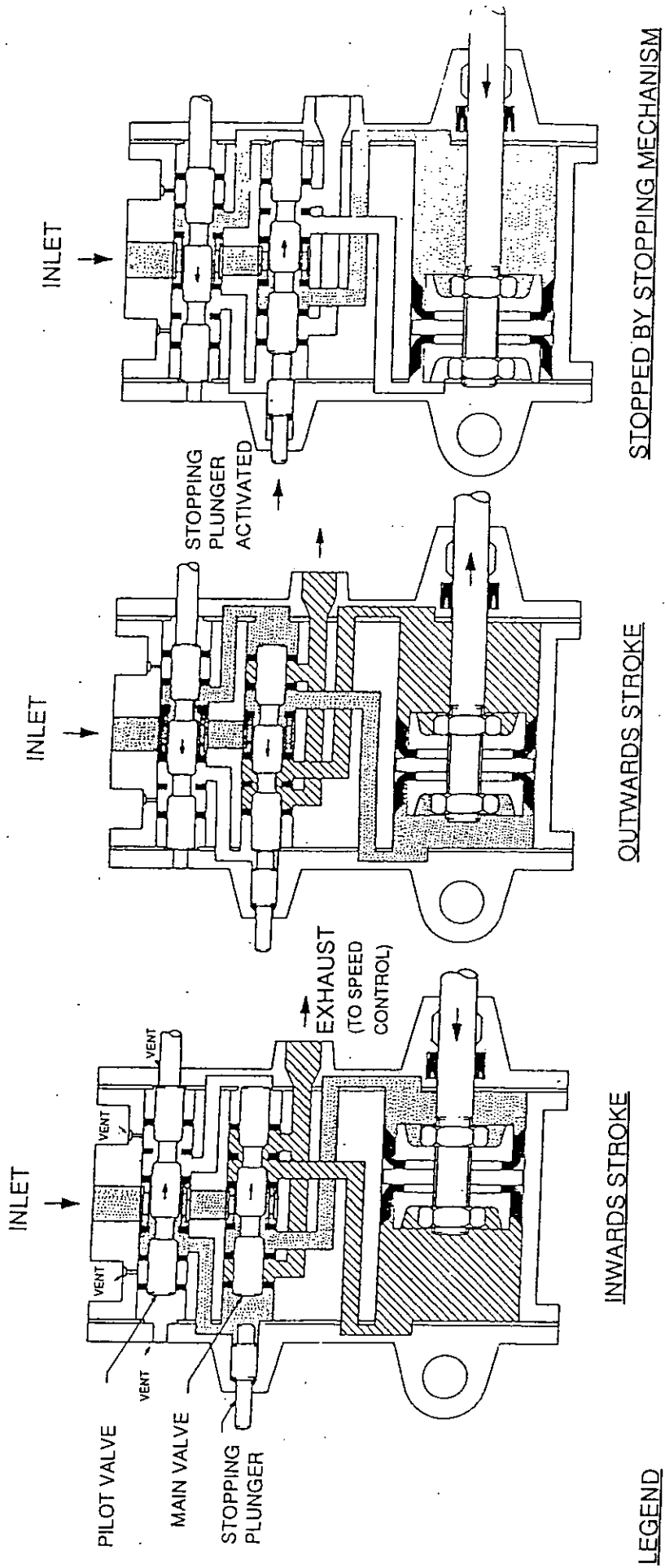

- LEGEND**
- INLET WATER - [White Box]
 - EXHAUST WATER - [Hatched Box]
 - VENT - [White Box]

WATER MOTOR HYDRAULIC DIAGRAM
SX 30 TRAVELLING IRRIGATOR

PARTS LIST

SX - 30 TRAVELLING IRRIGATOR

Replacement Parts For Irrigators

When ordering parts, it is important to supply the following information:-

Symbol Number and Name of Part - from the Parts List.
Serial Number - The Serial Number is branded near the front of the irrigator.
Size of Hose used with Irrigator.

No. Per Unit	Symbol Number	Name of Part
1	PCC1B	Chassis
2	KLA3B	Hose Coupling Latch
2	KLA4	Hose Coupling Latch Pin
1	LLD8	Speed Control Needle Spring
1	PCC9	Standpipe - Top Half
1	KLA11	Female Hose Connection Sealing Ring
1	KCD12	Hydraulic Motor Top End Cap Plug
1	PCC12	Driving Unit Spacer
2	PCC13	Hydraulic Motor Bucket
1	PCC16	Axle to Chassis U-bolt
1	PCC17	Axle Retaining Plate
1	PCC20D	Axle
1	PCC24	Hose Tensioning and Axle Mounting Bracket
1	PCC25	Hose Tensioning Roller
1	TCD25	Pressure Gauge
1	PCC27	Cable Guide
3	PCC28	Hose Reel Mounting Plate to Chassis Standpipe U-Bolt (2) Cable Guide to Chassis U-bolt (1)
2	PCC30	Hose Reel Rim
As req'd	PCC33	Hydraulic Motor Pivot Spindle Washer Rocker Arm Spindle Washer
1	PCC34	Cable Guide Spacer
1	PCC35B	Hose Reel Hub - Plain Half - 1-3/4 inch Hose (as ordered)
1	PCC36B	Hose Reel Hub - Geared Half - 1-3/4 inch Hose (as ordered)
1	PCC37	Hose Reel Retaining Setscrew
1	PCC38C	Hose Reel Mounting Bracket and Spindle
1	PCC49	Hose Reel Retaining Setscrew to Axle Tie Bar
6	LGB51	Canopy Bolt
1	PCC55	Stopping Plunger
1	PCC56	Stop Rod Trip Lever
1	PCC58	Stopping Lever Spring Mount
1	PCC59	Stopping Lever Spring
1	PCC60B	Stop Rod
1	PCC64	Stopping Lever
1	PCC69B	Driving Unit
1	PCC71	Rocker Arm
2	PCC73	Driving Arm (Short)
2	PCC74	Driving Arm (Long)
5	PCC75	Driving Arm Bush
2	PCC76B	Pilot Valve Control Arm Bush
1	PCC78	Plunger Rod
1	PCC79	Plunger Rod Nut
1	PCC80	Plunger Rod to Rocker Arm Connecting Spindle

No. Per Unit	Symbol Number	Name of Part
1	PCC81	Pilot Valve Control Rod
1	PCC82B	Pilot Valve Control Arm
2	PCC85B	Hydraulic Motor Pivot Pin (l) Rocker Arm Spindle (l)
2	PCC86B	Plunger Rod Bucket Backing Plate
1	PCC87B	Plunger Rod Bucket Spacer
1	PCC88	Hydraulic Motor Pivot End Cap
1	PCC89	Hydraulic Motor Top End Cap
1	PCC90	Hydraulic Motor Body
2	PCC91	Hydraulic Motor End Cap Gasket
1	PCC93	Pilot Valve
1	PCC94	Pilot Valve Spacer (Inner)
2	PCC95	Pilot Valve Spacer (Outer)
1	PCC96	Spool Valve
2	PCC97	Spool Valve Spacer (Outer)
1	PCC98	Spool Valve Spacer (Inner)
1	PCC100C	Cable Drum
1	PCC101B	Cable Drum Side Plate
1	PCC102C	Cable Drum Spindle
1	PCC103B	Cable Drum Brake
1	PCC104B	Cable Drum Brake Spindle
2	PCC106	Cable Clamp
8	PCK108	Pilot Valve Lantern Ring (4) Spool Valve Lantern Ring (4)
1	PCC113B	Cable Anchor
1	PCC114C	Stopping Plate
1	PCC118	Anchor Post Link
3	PCC120	Inlet and Exhaust Hose Connection
1	PCC122B	Filter to Hydraulic Motor Hose
1	PCD123B	Hydraulic Motor Exhaust to Speed Control Valve Hose
16	DNE125	Hydraulic Motor End Cap Setscrew Washer
1	PCD126	Speed Control Valve Body
1	PCD129	Speed Control Needle
1	PCD130	Speed Control Spring Retaining Washer
2	PCC136	Pilot Valve Control Arm Adjusting Nut
2	PCC140	Male Hose Coupling 1-3/4 in. Hose (as ordered)
1	PCD141	Speed Control Valve Bracket
1	PCC146	Cable Drum Brake Spring
1	PCC147	Cable Drum Spring Location Pin
1	PCD150	Cable
1	PCC155	Filter Body
1	PCC160	Filter
1	PCC161	Filter Body Gasket
1	PCC171	Driving Unit Brace Spacer
1	PCC174B	Foliage Guard
1	PCC175	Foliage Guard Retaining Setscrew
1	PCC180	Canopy Stay Assembly
1	PCC181	Canopy Clamp Bar
1	PCC186	Canopy
1	PCC200	Control Arm Slide
1	PCC201	Control Arm Slide Support
1	KLC206	Plunger Rod Seal
1	PCC317	Hose Reel Spacer - 1-3/4 in. Hose (as ordered)
1	PCC318	Hose Reel Hub - Plain Half - 2 in. Hose (as ordered)
1	PCC319	Hose Reel Hub - Geared Half - 2 in. Hose (as ordered)
2	PCC320	Hose Coupling - 2 in. Hose (as ordered)
2	PCC343	Wheel
4	PCC344	Wheel Bearing
1	PCK380	Pilot Valve Rod Coupling

<u>No. Per</u>	<u>Symbol</u>	<u>Name of Part</u>
<u>Unit</u>	<u>Number</u>	
12	PCK383	Pilot Valve Seal (6)
		Spool Valve Seal (6)
1		Pilot Valve Control Arm Bolt (1-3/4 in. x 1/4 in. - Whit. Bolt and Nut)
3		Hose Reel Hub Clamping Bolt - 1-3/4 in. Hose (as ordered) (4-1/2 in. x 3/8 in. Whit. Bolt and Nut)
3		Hose Reel Hub Clamping Bolt - 2 in. Hose (as ordered) (5 in. x 3/8 in. Whit. Bolt and Nut)
2		Driving Unit Base Mounting Bolt (Short) (1-1/2 in. x 1/2 in. Whit. Bolt and Nut)
1		Driving Unit Base Mounting Bolt (Long) (8 in. x 1/2 in. Whit. Bolt and Nut)
6		Cable Drum Side Plate Mounting Setscrew (1 in. x 3/8 in. - 16 UNC H. Tensile)
12		Hydraulic Motor End Cap Setscrew (Short) (7/8 in. x 5/16 in. - 18 UNC H. Tensile)
2		Stop Rod Trip Lever Setscrew (1) Stopping Plunger Adjusting Setscrew (1) (1 in. x 5/16 in. - 18 UNC H. Tensile)
18		Hose Reel Rim Mounting Setscrew (16) Hydraulic Motor End Cap Setscrew (Long) (2) (1-1/4 in. 5/16 in. - 18 UNC H. Tensile)
5		Driving Arms Clamping Bolt (1-3/4 in. x 5/16 in. - 24 UNF Bolt without Nut, H.Tensile)
1		Cable Drum Cable Clamp Setscrew (1-1/4 in. 3/8 in. - 16 UNC H. Tensile)
1		Cable Clamp Setscrew (1-1/4 in. 3/8 in. - 16 UNC H. Tensile)
4		Filter to Chassis Bolt (1-1/2 in. x 3/8 in. Whit. Bolt and Nut)
1	U	Cable Drum Brake Adjusting Setscrew (1-3/4 in. x 3/8 in. Whit.)
2		Control Arm Slide Setscrew (1-3/4 in. x 1/4 in. Whit)
1		Rocker Arm Spindle Setscrew (3/4 in. x 3/8 in. - 16 UNC)
1		Stopping Lever Spindle Stud (2-5/8 in. x 3/8 in. - 16 UNC)
18		Stop Rod Trip Lever Nut (1) Hose Reel Rim Mounting Setscrew Nut (16) Stopping Plunger Adjusting Setscrew Nut (1) (5/16 in. - 18 UNC)
8		Chassis to Axle U-Bolt Nut (2) Hose Reel to Standpipe U Bolt Nut (4) Cable Guide to Chassis U-Bolt Nut (2) (3/8 in. Whit)
3	V	Cable Clamping Setscrew Nut (2) Cable Drum Brake Adjusting Setscrew Locknut (1) (3/8 in. - 16 UNC)
2		Pilot Valve Locknut (1) Pilot Valve Control Rod Locknut (1) (3/8 in. - 16 UNC Brass Nut)
1		Stopping Lever Spindle Stud Nut (3/8 in - 16 UNC 'Nyloc')
5		Driving Arm Clamping Bolt Nut (5/16 in. - 24 UNF Thin 'Nyloc')
2	S	Plunger Rod Bucket Retaining Nut (5/8 in. Whit. Brass Locknut)

No. Per Unit	Symbol Number	Name of Part
2		Control Arm Slide Washer (1/4 in. M.S. Plain)
2		Stopping Lever Spindle Stud Nut Washer (1) Rocker Arm Spindle Washer (1) (3/8 in. M.S. Plain)
1		Tensioning Roller Spindle Washer (3/4 in. M.S. Plain)
6		Canopy Washers (5/16 in. M.S. Plain)
2		Stub Axle Washer (1 in. M.S. Plain)
1		Pilot Valve Control Arm Spring Washer (1/4 in. x 1/16 in. x 1/16 in. Spring)
16		Hose Reel Rim Mounting Setscrew Spring Washer (5/16 in. x 3/32 in. x 3/32 in. Spring)
23		Hose Reel to Standpipe U-bolt Spring Washer (4) Hose Reel Hub Clamping Bolt Spring Washer (3) Chassis to Axle U-bolt Spring Washer (2) Cable Clamp Setscrew Spring Washer (2) Cable Guide to Chassis U-bolt Spring Washer (2) Cable Drum Side Plate Mounting Setscrew Washer (6) Filter to Chassis Bolt Spring Washer (4) (3/8 in. x 3/32 in. x 3/32 in. Spring)
2		Driving Unit Base Mounting Bolt Spring Washer (1/2 in. x 1/8 in. x 1/8 in. Spring)
2		Hose Reel Retaining Setscrew Spring Washer (1) Cable Drum Retaining Setscrew Washer (1) (3/4 in. x 3/16 in. x 3/16 in. Spring)
3	A	Tensioning Roller Circlip (1)
	B	Rocker Arm Retaining Circlip (1)
	C	Hydraulic Motor Pivot Circlip (1) (Anderton External Type 1400 - 19MM Shaft)
4	E	Filter to Hydraulic Motor Hose Clip (2)
	F	Hydraulic Motor Exhaust to Speed Control Valve Hose Clip (2) (‘Utilux’ Stainless Steel Hose Clip, Worm Drive No. 00 Cat. No. 4039)
5	W	Speed Control Valve Body Support Retaining Clip (1)
	G	Hose Coupling Clip (4) (‘Utilux’ Stainless Steel Hose Clip - Worm Drive No. 4042)
1		Speed Control Valve Body Retaining Clip (‘Utilux’ S.S. Hose Clip - Worm Drive No. 4040)
2	Z	Foliage Guard Mounting Clip (‘Utilux’ Stainless Steel Hose Clip - Worm Drive No. H4043)
2		Stub Axle Split Pin - 40 x 5mm (Br. M.S. Cotter Pin)
1		Speed Control Valve Operating Handle Pin (1-1/4 in. x 3/16 in. Tension Pin)
1	H	Hydraulic Motor Stopping Plunger Sealing Ring (‘Lurene’ 6227 Series O - 5 ‘O’ Ring)
1	M	Hydraulic Motor Exhaust Bend (3/8 in. B.S.P. M & F Galv. Bend)
1	Q	Pressure Gauge Cock (1/4 in. x 1/4 in. B.S.P. Stop Cock)
1	R	Pressure Gauge Tee (1/4 in. BSP Galv. Tee)
1	Y	Pressure Gauge Vent Cock (Turner No. 30 Drain Cock)

No. Per Unit	Symbol Number	Name of Part
9		Rocker Arm Grease Nipple (3) Hydraulic Motor Pivot Spindle Grease Nipple (1) Hose Reel Spindle Grease Nipple (1) Wheel Grease Nipple (2) Cable Drum Spindle Grease Nipple (1) Tensioning Roller Grease Nipple (1) (1/8 in. B.S.P. Straight Grease Nipple)
2		Hydraulic Motor Plunger Rod Grease Nipple (1) Plunger Rod to Rocker Arm Connecting Pin Grease Nipple (1) (1/8 in. B.S.P. x 90 deg. Grease Nipple)
1	J	Chassis Skid Plate Plug (1/4 in. B.S.P. Galvanised Taper Plug)
1	N	Standpipe to Sprinkler Socket (1-1/4 in. B.S.P. Galvanised Socket)
1	T	Pressure Gauge Reducing Bush (3/8 in. x 1/4 in. B.S.P. Galvanised Reducing Bush)
1	P	Standpipe to Standpipe Top Half Reducing Socket (2 in. B.S.P. / 1-1/4 in. B.S.P Galvanised Reducing Socket)
2		Tyre (400 x 8 - 4 Ply Block Pattern Tyre, with Tube)

SPRINKLER AND NOZZLES

No. Per Unit	Symbol Number	Name of Part
1		Sprinkler - Part Circle (Rainbird Model 85 EW - TNT 1-1/4in.- Part Circle)
1		Nozzle.
As required		Nozzles available: 11/32, 3/8, 13/32, 7/16, 15/32, 1/2, 17/32, 9/16, 5/8 (inches)

HOSE

No. Per Unit	Symbol Number	Name of Part
1		1-3/4 in. Hose - Angus Tractor Hose 1-3/4 in. x 330 ft. Coil (as ordered)
1		2 in. Hose - Angus Tractor Hose 2 in. x 330 ft. Coil (as ordered)

HOSE JOINER

No. Per Unit	Symbol Number	Name of Part
1	PCC142	Hose Joiner 1-3/4 in. Hose (as ordered)
1	PCC321	Hose Joiner 2 in. Hose (as ordered)
4		Hose Joiner Clip (Utilux Stainless Steel Worm Drive Hose Clip - no. 4042)

MAINLINE STARTING COUPLINGS**1 in. B.S.P.**

<u>No. Per</u>	<u>Symbol</u>	<u>Name of Part</u>
<u>Unit</u>	<u>Number</u>	
1	KLA10B	1 in. B.S.P. Starting Coupling
1	KLA11	Starting Coupling Sealing Ring
		Starting Coupling Plug - (1/2 in. B.S.P. Galv. Plug)

MAINLINE STARTING COUPLINGS**2 in. B.S.P.**

<u>No. Per</u>	<u>Symbol</u>	<u>Name of Part</u>
<u>Unit</u>	<u>Number</u>	
1	PCC110	2 in. B.S.P. Mainline Starting Coupling Body
1	KLA11	Starting Coupling Sealing Ring

MAINLINE STARTING COUPLINGS**3 in. Pipe**

<u>No. Per</u>	<u>Symbol</u>	<u>Name of Part</u>
<u>Unit</u>	<u>Number</u>	
1	KLA11	3 in. Starting Coupling Sealing Ring
1	KLC14	3 in. Starting Coupling to Pipe Clamp Plate
1	KLC15	3 in. Starting Coupling to Pipe Clamp U-bolt
1	KBC26	3 in. Pipe Sealing Ring
1	PCC214	3 in. Pipe Mainline Starting Coupling Body
2		3 in. Starting Coupling to Pipe Clamp U-bolt Nut (5/16 in. Whit)
2		3 in. Starting Coupling to Pipe Clamp U-bolt Washer (5/16 in. Plain)

