



## Emflux M300 Flowmeter Transmitter

Comprehensive range of electromagnetic flowmeters to suit applications from water to abrasive and corrosive process fluids.

## Features

- The Emflux flowmeter uses the well proven electromagnetic method of measurement, which applies Faraday's Law as the principle of operation. This technique features a straight through section of pipe with no obstruction to restrict flow, and no moving parts to wear or break.
- Highly accurate. 0.2 % of rate from 0.5 to 10 metres (1.65 to 33 feet) per second.
- Integral keypad standard. All configuration is performed via front keypad. No plug-in programmer required.
- 32 character display standard, displays rate, total and diagnostic messages.
- Display guides operator with menu prompts during configuration.
- Comprehensive output options. Include multiple analogue, relay, digital and serial outputs.
- Self calibrating system with simple in-field verification.
- Self monitoring & diagnostic functions. Constantly monitors system integrity and measurement validity. Diagnostics can be linked to outputs for diagnostic alarm.
- Flexible mounting options. Wall or panel mounting system standard.
- Bi-directional flow standard.
- Accredited under the Standards Australia Supplier Assessment scheme to ISO9002, ensuring our customers receive a high level of support and quality.

## General Applications

Electromagnetic flowmeters for the accurate flow measurement of any conductive fluid. Ideally suited to water and waste water treatment plants, mining and general industry.

## Technical Data

**Display:** 32 character (2 line x 16 character) alpha-numeric backlit LCD. Displays rate of flow, total flow, alarms, diagnostic messages analogue outputs and relay annunciators. Displays text prompts in programming mode.

**Configuration:** All functions are accessible via 3 button integral keypad. A logical 2 level menu system with display prompts ensures ease of configuration.

**Outputs:** 1 x 4 - 20 mA. Second 4 - 20 mA output optional. (Each fully isolated, max. load 1000 ohms) 2 x relays with change over contacts. 4 x relays optional. (1.0 A, 30 VDC. Selectable for dry contact or 24 V pulse).

Configurable for:

- Empty pipe detection.
- Forward/reverse flow detection.
- Hi/low alarm, (deadband adjustable)
- Totaliser output.
- System fault, diagnostic alarm.

2 x Digital, open collector. (Configurable as frequency [0 - 1000 hz] or pulse outputs 100 mA, 60 VDC. 24 V available for sourcing). 1 x RS485/RS232.

**Power supply:** 24 VAC/DC. 85 - 265 VAC 50 / 60 Hz. ( $\pm 20\%$ ). Power consumption, 25 va.

**Enclosure:** Rated IP65. Surface or panel mounting.

**Accuracy:**  $\pm 0.2\%$  of rate or  $\pm 0.001$  metres ( $\pm 0.003$  feet) per second, whichever is greater, from 0.5 to 10 metres (1.65 to 33 feet) per second.

**Battery operation:** The M300 can function from a 24VDC battery power supply. The M300 will take a reading from the flowtube, turn off the power supply to the tube, and hold this reading, indicating and totalising at this rate for the 'switch off'. This switch off period is adjustable to suit the particular dynamics of the flow application, and maximize battery life. Two 60AH 12V batteries will power the flowmeter for a period of 2 weeks, based on a 10 min update time. Using a solar panel the system can run continuously without mains power.

**Velocity/Accuracy Graph**

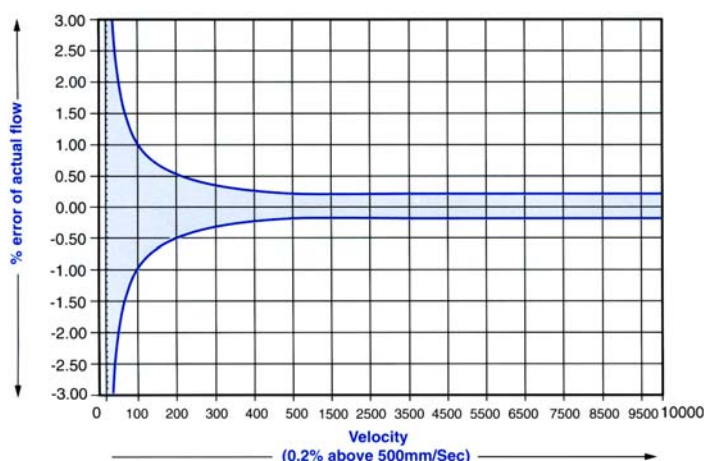

Resolution	18 bit.
Linearity	< 0.05%
Repeatability	< 0.05%
Temp, stability	< 0.05% range, minus 10-55°C (14-131°F)
Voltage effects	Negligible
Turndown from FS	> 1000:1
Separation	100 metres (328 feet).
Conductivity	5µS/cm.

## Set-up and Operation

The operation and set-up of the system are broken into two main areas:

### Commissioning Mode

Only accessible through a 3 digit security code to avoid unauthorised access. This mode is used to set the Flow System to your application requirements, including Flow Range, Flow Units, Response Time, Simulations, Outputs etc. Settings may be made either direct via the three button keypad or remotely using the Comms Port and a computer. When information is provided, the M300 is supplied configured to customer requirements.

### Operations Menu

Displays readings in normal run mode. The default display shows the Flowrate and Totaliser with an indication of Forward / Reverse Flow. The operator may also call up other displays, using the up/down arrow key, such as

- Reverse Total
- Output Signals
- Nett Totaliser
- Diagnostics and Alarms
- Rate/Velocity
- Run Time Hours

The display automatically reverts back to default display after two (2) minutes.

### Diagnostics

The M300 incorporates advanced diagnostics which monitor the integrity of the system, including:

- Detector Head Current
- Detector Head Cabling
- Internal Reference Voltages
- A to D Conversion

### Configuration options

- Detector Head Size
- Low-flow Cut-off
- Detector Head Constant
- Failsafe Modes
- Flow range
- Relay functions
- ResponseTime
- Outputs

The LCD display and integral keypad allows the user complete control over all configurable functions. Self calibrating electronics and self diagnostics ensure the system maintains integrity at all times. Simple in-field verification available.

### Automatic electrode cleaning

A high frequency applied to the Electrodes between each measurement cycle is used to continuously clean the electrodes. This feature removes the errors caused by coating which typically occurs in many applications.

### Operator interface

The M300 includes an integral 2 line alphanumeric display and keypad as standard. No plug in programmer is required. Password protection is included to prevent unauthorized tampering. All parameters are sequenced in a logical, easy to follow order. Configuration prompts on the display further simplifies set-up.

## Dimensions (mm)

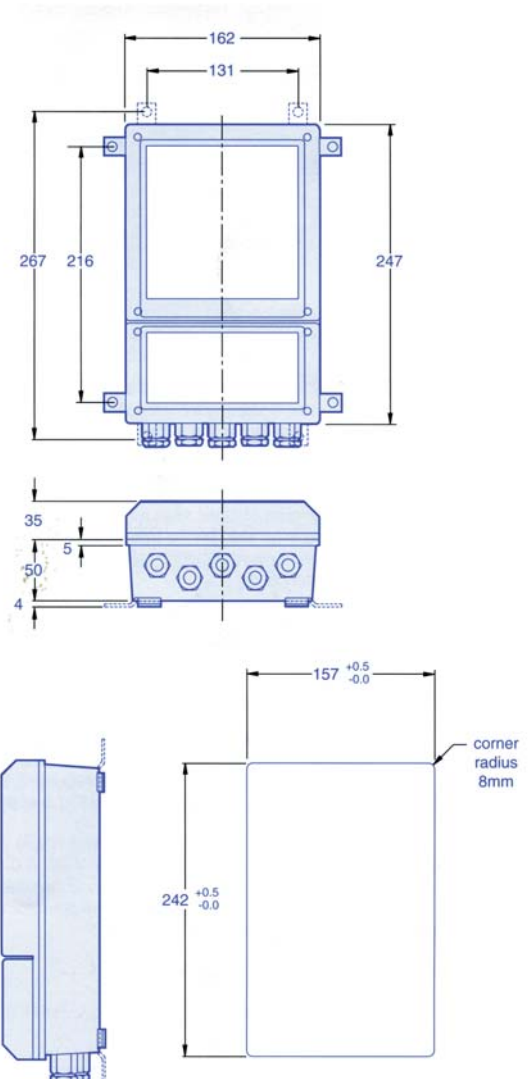

### Typical specifying sequence

Example:	M300 -	L	1A	2R	F	R	K
<b>Power Supply</b>		↑	↑	↑	↑	↑	↑
L = 24 AC/DC (standard)							
M = 85 to 265 VAC 50 Hz (60 Hz optional)							
B = Battery powered (Includes configurable coil on/off timer)							
<b>Analogue output</b>			↑	↑	↑	↑	↑
1A = 1 x 4 to 20 mA (standard)							
2A = 2 x 4 to 20 mA							
<b>Relay outputs</b>				↑	↑	↑	↑
2R = 2 x relays (standard)							
4R = 4 x relays							
<b>Flowmeter type</b>					↑	↑	↑
F = Full Pipe MagFlow Tube							
<b>Mounting options</b>						↑	↑
R = Remote transmitter							
<b>Special function</b>							↑
K = (ie. empty pipe detection, 60 Hz line frequency)							



### Australia Head Office

Goyen Controls Co Pty Ltd  
268 Milperra Road  
Milperra, NSW 2214

Telephone: 1800 805 372  
Facsimile: 1300 658 799

### Queensland

Telephone: 1800 805 372  
Facsimile: 1300 658 799

### Victoria

Telephone: 1800 805 372  
Facsimile: 1300 658 799

### South Australia

Telephone: 1800 805 372  
Facsimile: 1300 658 799

### Western Australia

Telephone: 1800 805 372  
Facsimile: 1300 658 799

### Asia

Goyen Controls Co Pty Ltd  
Shanghai Representative Office  
2521 Zhao Feng World Trade Building  
369 Jiang Su Road Shanghai 200050 CHINA

Telephone: 86 21 5239 8810  
Facsimile: 86 21 5239 8812

Goyen Controls Co Pty Ltd  
65-2 Jalan Mega Mendung  
Kompleks Bandar 58200  
Kuala Lumpur MALAYSIA

Telephone: 60 37 987 6839  
Facsimile: 60 37 987 7839

### Office

Singapore

Telephone: 65 6457 4549  
Facsimile: 65 6457 4549

### Europe

Goyen Controls Co UK Ltd  
Unit 3B Beechwood  
Chineham Business Park  
Basingstoke, Hampshire, RG24 8WA  
UNITED KINGDOM

Telephone: 44 1256 817 800  
Facsimile: 44 1256 843 164

Tyco Umwelttechnik GmbH  
Im Petersfeld 6  
D-65624 Altendiez  
GERMANY

Telephone: 49 6432 1001/1002  
Facsimile: 49 6432 63810

### USA

Goyen Valve Corporation  
1195 Airport Road  
Lakewood  
New Jersey 08701 USA

Telephone: 1 732 364 7800  
Facsimile: 1 732 364 1356