



Emflux I300 Solar Powered Transmitter

Solar powered transmitter for use with the Emflux range of Electromagnetic Flow Detector Heads. Designed to meet the requirements of remote and non-powered site applications.

Features

- Uses the well proven electromagnetic method of measurement, which applies Faraday's Law as the principle of operation.
- Operates on batteries and a solar panel.
- High accuracy.
- Multiple outputs
- Pulse
- Frequency
- 4 - 20mA
- Serial comms at TTL level
- Radio ready
- Integral keypad for configuration and operation with password protection.
- Simple set-up and operation.
- Self calibrating electronics.
- Optional remote visual flowrate indication (from up to 30 metres [98.5 feet]).
- Weatherproof stainless steel construction to IP65.
- Tamperproof design with lockable door.
- Double layered enclosure (on 3 sides and top).
- Concealed mounting bolts for both the sunshield and the inner enclosure. (Difficult to remove from pole and remove solar panel).
- Cable entry via mounting post and directly into rear of enclosure (No exposed cables).
- Solar panel can not be removed without fully disassembling enclosure and sunshield.
- Reset monitor counts the number of times the battery has been disconnected from the system also the hours since last reset.
- No moving parts.
- Not effected by water purity.

General Applications

- Irrigation, on and off farm flow measurement.
- Mining, remote water supplies and discharge monitoring.
- Pipeline leakage detection.
- Water Bore flow monitoring.
- Environmental flow measurements.
- Water and wastewater.

System Configuration

The transmitter comes completely packaged including a weather shield to protect the electronics enclosure from direct sunlight, rain and hail. The Solar panel is installed as an integral part of the weather shield.

The inner fully sealed box houses the battery and electronics. Mounting brackets are included to enable connection to a 50mm (2in) mounting pipe.

Cabling from the detector head enters the enclosure via the mounting pipe.

Specifications

Displays	2 Lines x 16 character alphanumeric LCD
Flow rate in:	Megalitres per day x 0.1 Revs per minute x 0.1 Litres per second x 0.1 Cubic metres per hour x 0.1 Metres per second x 0.1
Flow total in:	Megalitres x 0.001 Cubic metres
Battery volts	
Solar panel volts	
Output	4-20 mA, externally powered, 12 to 24VDC (max) required
Pulse	Digital 5 to 24VDC open collector output opto isolated. 20 mA max current. Programmable up to 5 pulses per second. Pulse width fixed at 50mS. (Used with optional flashing remote indicator)
Frequency	Open collector, 24VDC max. 100mA max current. Programmable up to 650Hz 50/50 duty cycle. Minimum output frequency = 5Hz.
Serial comms at TTL level, remote access to real time data.	
Flowrange	0.03 to 5.0 m/sec (0.1 to 16.4 ft/sec).
Power supply	12 VDC from 7ah battery and 5 watt solar panel
Current draw	10 mA average, based on 10 min. update time and no options.
Enclosure	Pipe mounting 304 stainless steel. IP65 weatherproof 300H x 200D x 240W. With sunshield and pipe mounting hardware.
Transmitter/detector separation	To a maximum of 30 metres (98.5 ft)
Operating temperature	0 to 55°C (0 to 131°F)
Minimum process conductivity	5 microsiemens per cm
Pipe not full detection	Standard feature in transmitter. Detection of a pipe that is not full will drive flow readings and outputs to zero.

Note: Requires detectors with pipe not full electrode option.

System set-up and operation

The transmitter is supplied pre-commissioned to suit your application requirements. Any required setup changes can be performed using the integral keypad. To conserve power the system periodically samples the flowrate. The reading and outputs are held between samples which occur at configured intervals of 15 seconds to 60 minutes. Readings may also be manually updated simply by pressing a display button.

Options

Peak/Off-Peak Totalisers: Provides flow consumption information during electricity peak and off-peak periods.

Latch Totalisers: Locks in the current flow total either on a monthly or yearly basis. This allows meter readers either one month or a year to read the flow total at a pre-determined time before it is overwritten.

Data Logging: An internal data logging capability that stores up to 2,032 records at one programmable time period. Data can be downloaded into a PC or PDA without the use of special software.

Remote Visual Indicator: A high Intensity LED is installed in the door of the enclosure and flashes at a rate proportional to flowrate. The actual rate is configured by the user to suit the application. For example in the case of a Dethridge Wheel replacement, the flash rate can be set to simulate the turning blades of the wheel. This enables the flowrate to be viewed remotely simulating the Dethridge wheel. The LED can be viewed up to distances of 30 metres (98.5 feet). The viewing angle is limited to eight degrees, to prevent the flashing becoming a potential problem to local residences.

Radio Communication (RTU): The transmitter can also be a RTU (Remote Telemetry Unit). As an option the transmitters electronic circuit can include a radio modem. This feature will allow a radio transmitter/receiver to be plugged directly into the system. A space in the rear of the enclosure has been allowed to fit the radio, which is powered from the existing solar panel and battery. The radio communicates using a Modbus RTU protocol enabling it to communicate with many existing telemetry systems. Information that can be collected includes:

- Flow Rate
- Flow Total
- Solar Panel Volts
- Battery Volts
- Resets
- Diagnostic Messages

With the appropriate equipment available from third party wireless solution providers, it is possible to provide for internet access to flow information.

4-20 mA Output: This provides a signal proportional to flowrate. This option requires a remote 12 VDC to 24 VDC (depending on loop load) power source. The output is always zero based, ie. 4 mA = 0 L/sec, with the span being programmable up to a maximum velocity of 5 metres (16.4 feet) per second.

Dimensions (mm)

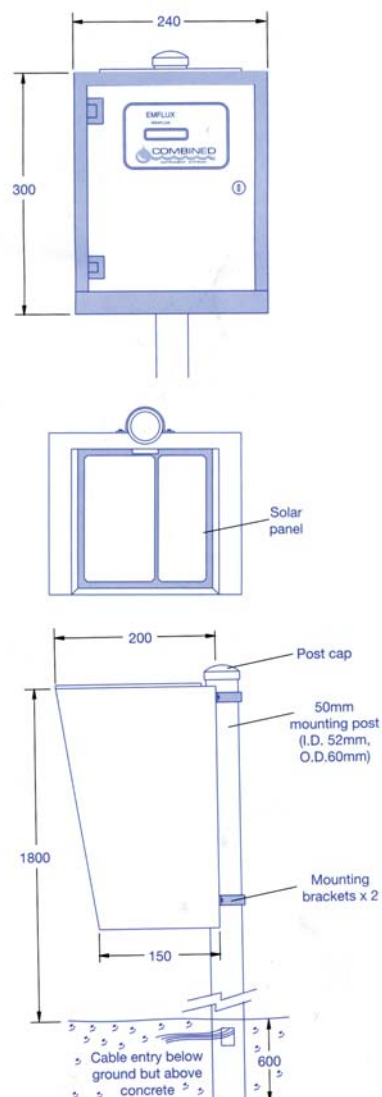

Typical specifying sequence

Example:	I300	I	1	X	X	X	Z
Solar Panel		↑	↑	↑	↑	↑	↑
I = Integral Mounted (std)							
R = Remote Mount Kit							
X = No solar panel or mounting brackets							
Totaliser			↑				
1 = Single Totaliser (std)							
2 = Peak/Off-Peak Totalisers, Data Logging							
Flashing LED				↑	↑	↑	
X= None							
L = With Flashing LED							
Analogue Output					↑	↑	
X= None							
A = With single 120mA Output							
Integral Radio							↑
X= None							
R = With Radio							
Special Function							↑
Z = Special Features not included above. Data in text.							
Note: Each 1300 transmitter comes complete with:- 12V 7AH sealed lead acid battery, 5 Watt 12 V solar panel and pipe mounting brackets and sunshield.							



Australia

Head Office

Goyen Controls Co Pty Ltd
268 Milperra Road
Milperra, NSW 2214

Telephone: 1800 805 372
Facsimile: 1300 658 799

Queensland

Telephone: 1800 805 372
Facsimile: 1300 658 799

Victoria

Telephone: 1800 805 372
Facsimile: 1300 658 799

South Australia

Telephone: 1800 805 372
Facsimile: 1300 658 799

Western Australia

Telephone: 1800 805 372
Facsimile: 1300 658 799

Asia

Goyen Controls Co Pty Ltd
Shanghai Representative Office
2521 Zhao Feng World Trade Building
369 Jiang Su Road Shanghai 200050 CHINA

Telephone: 86 21 5239 8810
Facsimile: 86 21 5239 8812

Goyen Controls Co Pty Ltd
65-2 Jalan Mega Mendung
Kompleks Bandar 58200
Kuala Lumpur MALAYSIA

Telephone: 60 37 987 6839
Facsimile: 60 37 987 7839

Office

Singapore

Telephone: 65 6457 4549
Facsimile: 65 6457 4549

Europe

Goyen Controls Co UK Ltd
Unit 3B Beechwood
Chineham Business Park
Basingstoke, Hampshire, RG24 8WA
UNITED KINGDOM

Telephone: 44 1256 817 800
Facsimile: 44 1256 843 164

Tyco Umwelttechnik GmbH
Im Petersfeld 6
D-65624 Altdiez
GERMANY

Telephone: 49 6432 1001/1002
Facsimile: 49 6432 63810

USA

Goyen Valve Corporation
1195 Airport Road
Lakewood
New Jersey 08701 USA

Telephone: 1 732 364 7800
Facsimile: 1 732 364 1356