

# S-020 AUTOMATIC AIR RELEASE VALVE FOR SEWAGE

Guarantees complete separation of the liquid from the sealing mechanism by creating an air gap at the top of the valve.

- The air gap, guaranteed even under extreme conditions, is achieved by a conical body shape that maintains maximum distance between the liquid and the Sealing Mechanism; while obtaining minimum body length.
- Spring loaded joint between the stem and the upper float, to ensure that vibrations of the lower float will not unseat the automatic valve. Release of air will occur only after the accumulation of enough air.
- Funnel-shaped lower body ensures that the residue sewage matter will sink to the system and be carried away.
- Self cleaning mechanism.

Includes A.R.I patent: Rolling Seal Mechanism.

The valve may be flushed through a ball valve at the valve's lower part.

Reliable operation reduces water hammer incidents.

Lightweight, small dimensions, simple and reliable structure.

All inner metal parts made of stainless steel.

Standard steel body - baked polyester coating.

Available with a Stainless Steel body or rilsan and enamel coatings.

Threades: BSPT/NPT.

Flanges are available in BS/ISO/ANSI standards.

Working pressure range: 0.2-25 bar. (3-360 psi)

Available in 2" (50mm) - 4" (100mm).

## Ordering

**Upon ordering, please specify: model, size, working pressure, threads/flanges standard and type of liquid.**



EC50202000

Auckland NZ  
PH: (09) 919 7600  
FAX: (09) 919 7604

Distributed  
by: **aquaspec**  
www.aquaspec.co.nz 0800 353 966

Christchurch NZ  
PH: (03) 968 3230  
FAX: (03) 968 3231

## PARTS LIST AND SPECIFICATION

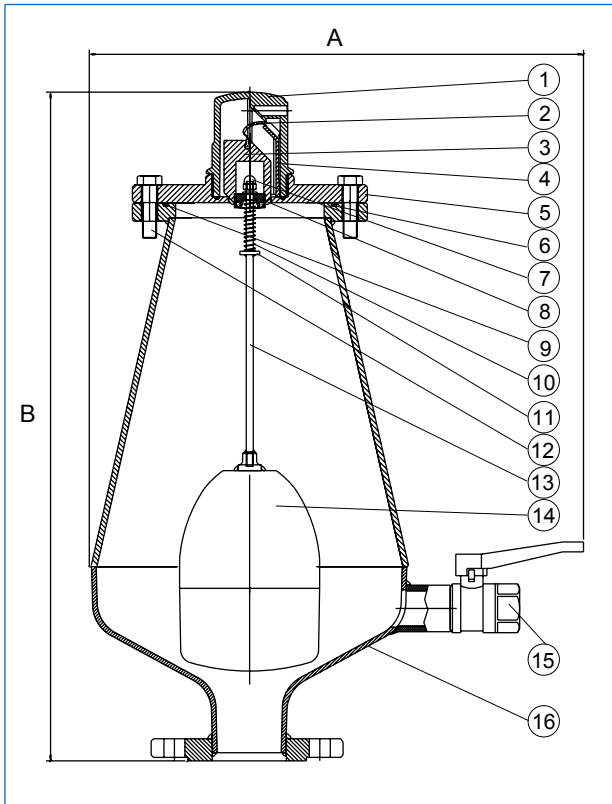

No.	Part	Material
1.	Body	Reinforced Nylon
2.	Rolling Seal	Rubber E.P.D.M.
3.	Float	Foamed Polypropylene
4.	Clamping Stem	Reinforced Nylon
5.	Cover	Steel DIN ST.37
6.	O-Ring	BUNA-N
7.	Crown Nut	Stainless Steel SAE 316
8.	Stopper	Acetal
9.	O-Ring	BUNA-N
10.	Spring	Stainless Steel SAE 316
11.	Washer	Stainless Steel SAE 316
12.	Bolt and Nut	Galvanized Steel Chromate Plated
13.	Stem	Stainless Steel SAE 316
14.	Float	Stainless Steel SAE 316
15.	Ball Valve	Brass ASTM B-124 / Polypropylene
16.	Body	Steel DIN ST.37

## AUTOMATIC AIR DISCHARGE CHART

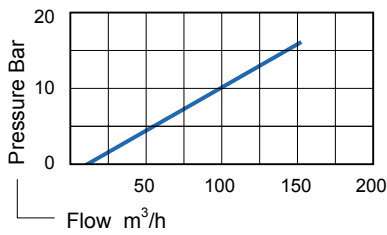

## DIMENSIONS AND WEIGHTS

Nominal Size	A	B	Weight Kg	Orifice Area mm <sup>2</sup>
50mm 2" Threaded	422	575	16.0	12
50mm 2" Flanged	422	575	17.0	12
80mm 3"	422	575	18.0	12
100mm 4"	422	575	19.0	12



Auckland NZ  
 PH: (09) 919 7600  
 FAX: (09) 919 7604

Distributed by: **aquaspec**  
 www.aquaspec.co.nz 0800 353 966

Christchurch NZ  
 PH: (03) 968 3230  
 FAX: (03) 968 3231