



Resilient seated Butterfly Valve, rated to 1600 kPa suitable for bi-directional and end of line service. Ideal for building services and irrigation applications.

KEYSTONE

Type:

F221 Wafer style valve.
F222 Lugged style valve.

Size Range:

50 - 300mm.

Pressure Rating:

Full vacuum to 1600 kPa
Bi-directional bubble tight shut-off rating.
Full 1600 kPa end of line shut-off capabilities with F222 lugged valve.

Temperature Rating:

Minus 30°C to 105°C.

Standard Flange Drilling:

AS 2129 E
ANSI class 125 and 150
JIS table 5 and 10*
PN 10 and 16*
Other drillings available upon request.
*Not available in all valve sizes.

Standard Actuation:

Handles (F401) on 50 - 200mm valves.
Gear operators (F427) on 250 - 300mm valves.



Valve trims

Trim No.	Body	Disc	Shaft	Seat	Bearing
784	Cast Iron	Aluminium Bronze	416 S/S	EPDM	Bronze
786	Cast Iron	316 S/S	416 S/S	EPDM	Bronze

Butterfly Valves - Figure 221 & 222

50 – 300mm

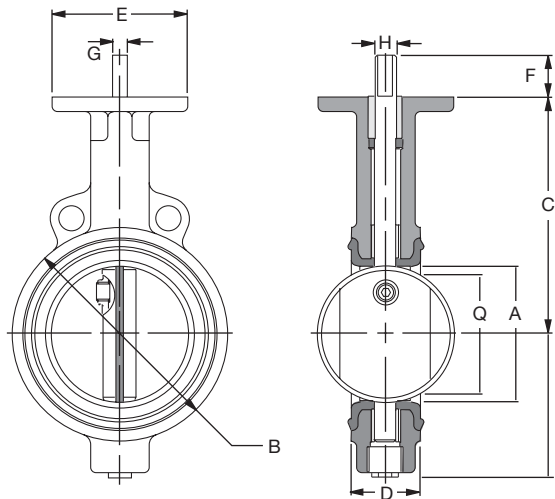

Note: F221 Wafer style valve illustrated

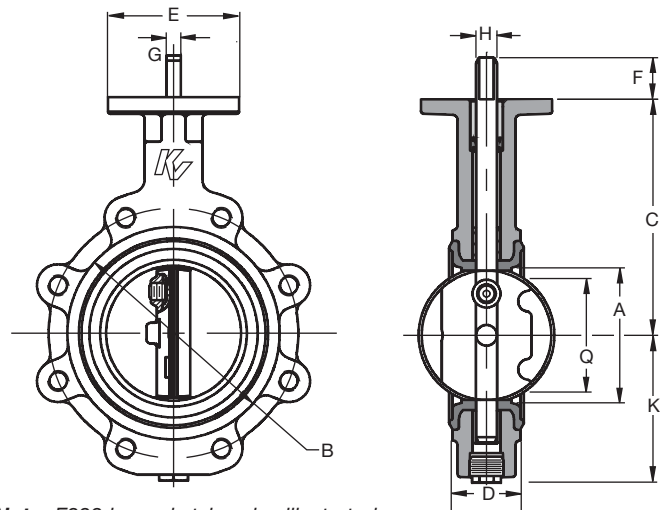

Note: F222 lugged style valve illustrated

Dimensions (mm)

Valve size	Stem conn. code	A	B	C	D	E	F	K	Q	Stem conn.		Top plate data			Mass (kg)		Kv value (fully open)
										H x G (inches)	Key (inches)	PCD. mm	No. holes	Hole dia.	F221	F222	
50	BAB	52	105	136	43	100	32	81	35	9/16 x 3/8	-	83	4	11	3.8	4.2	52
65	BAB	65	117	150	46	100	32	86	50	9/16 x 3/8	-	83	4	11	4.2	5.0	131
80*	BAB	78	132	160	46	100	32	95	67	9/16 x 3/8	-	83	4	11	5.0	5.4	227
100#	BAC	103	162	180	52	100	32	108	94	5/8 x 7/16	-	83	4	11	7.4	9.8	560
125	BAD	129	187	195	56	100	32	130	121	3/4 x 1/2	-	83	4	11	9.0	11.7	988
150	BAD	148	216	210	56	100	32	144	141	3/4 x 1/2	-	83	4	11	11.0	14.1	1368
200 [∞]	CAE	198	271	241	60	150	32	177	190	7/8 x 5/8	-	127	4	14	17.3	22.0	2504
250	CAF	249	330	276	68	150	50	208	241	1 1/8	1/4 x 1/4	127	4	14	26.2	34.5	3977
300	CAF	300	376	310	78	150	50	239	291	1 1/8	1/4 x 1/4	127	4	14	34.5	48.5	5785

Notes:

Q = The disc chordal dimension at face of valve for disc clearance into pipe fittings or flanges.

H = The stem connection diameter.

G = The dimension across the stem flats.

Kv = The flow rate of water in m³/hr that will pass through a valve with a pressure drop of 1 bar (100kPa) @ 20°C.

Cv = 1.155 Kv.

* Not available with PN10, PN16 or JIS 10 flange drilling.

Not available with JIS 5 flange drilling.

∞ Not available with PN16 or JIS 10 flange drilling.

Dimensions are nominal ± 1mm.

Anticipated seating and unseating torque values (Nm)

Valve Size (mm)	Shut off pressure (kPa)											
	Normal service						Severe service					
	0	350	700	1000	1400	1600	0	350	700	1000	1400	1600
50	13	14	14	15	16	17	33	33	34	35	35	36
65	17	18	19	20	22	23	42	43	45	46	47	48
80	20	21	23	25	27	28	49	51	53	54	56	58
100	31	34	37	40	44	47	76	80	83	86	90	93
125	50	56	63	69	75	81	126	132	138	144	151	157
150	66	75	84	93	102	111	165	174	183	192	201	210
200	176	195	214	232	251	269	441	459	478	497	515	534
250	298	336	373	411	448	486	746	783	821	858	896	933
300	339	393	447	501	555	609	847	901	955	1009	1063	1117

Notes:

1. The charted seating and unseating torques are the sum of all friction and resistance for opening and closing of the disc against the indicated pressure differential for normal and severe services respectively.

2. Normal Service:

Valve must be regularly operated on liquid service at moderate temperatures with no internal deposition or chemical attack.

3. Severe Service:

All other conditions including -

Dry service, infrequent operation, very low or high temperatures, any significant media build-up or chemical attack.

4. The relationship between values are linear, therefore you can interpolate between nominated values.

5. The effect of dynamic torque is not considered in tabulation.

6. In sizing operators it is not necessary to include safety-factors.