

PGV Valves

*Rugged, Professional-Grade Valves Designed to
Handle the Full Range of Landscape Needs*



Auckland NZ
PH: (09) 919 7600
FAX: (09) 919 7604

Distributed
by: **aquaspec**
www.aquaspec.co.nz 0800 353 966

Christchurch NZ
PH: (03) 968 3230
FAX: (03) 968 3231

TABLE OF CONTENTS

Product Overview	3
Features and Benefits	4
Accu-Set™ Dial Control Pressure Regulation	8
Accu-Set™ Installation Instructions	8
Product Comparisons	9
Technical Information	10
Installation Details	11
Valve Operation	12
PGV Replacement Parts	13

PRODUCT OVERVIEW

The same HUNTER quality found in all of our remote control valves is also found in the PGV family. This Professional Grade Valve is a solid, heavy-duty performer designed to satisfy the requirements of the most demanding job sites.

Meets the Needs of All Residential/Commercial Projects

The versatility of the PGV valve is the answer to anyone who demands options. The valve is offered as an angle, globe or globe/angle combination in a full range of sizes, including 1" with or without flow control, 1½", and 2". Flow capability ranges from a low of 1 gpm (0.23 m³/hr, 3.8 l/m) all the way up to 120 gpm (27.2 m³/hr, 454.2 l/m).

Available as an option, the Hunter Accu-Set™ valve pressure regulator is an important tool for the professional installer. The Accu-Set™ is the product of choice for installation on PGV valves when the static supply pressure is just too high for sprinkler operation or when the irrigation main lines need to be at maximum pressures due to long pipe runs. Also, the Accu-Set™ is the ideal pressure regulator to use when different irrigation zones require different outlet pressures due to product specifications, such as sprays and rotors. Easy to install and easy to read, this dial-in pressure regulating module automatically adjusts as needed to provide an accurate and consistent working pressure in the zone piping.

Designed for Years of Life

Hunter developed the PGV valve with its multitude of features, because of a market need for a strong product with dependable performance.

The rugged, extremely tough body and bonnet contribute to a high pressure rating of 150 psi (10.3 bars, 1034 kPa). In addition, the valve features captive bonnet screws,

diaphragm and a captive solenoid plunger. Plus, the heavy-duty Hunter solenoid, with its 5-year warranty, is sure to keep everything working for years and years.

Easy to Install, Easy to Maintain

Maintenance is an ongoing reality to any project and like all Hunter products, the easy-maintenance PGV was designed with the installation and service needs of the professional installer in mind. Offering a globe/angle configuration in one valve allows the installer to readily place the valve for easy access. The PGV's diaphragm, solenoid plunger, and bonnet screws are all captive parts, eliminating the chance of lost parts. Through-holes in the body allow dirt to fall through the screw holes instead of allowing it to pack at the bottom, where it can make it impossible to tighten the screw upon reassembly.

The bonnet screws used in the PGV line are unique to Hunter valves. These screws, specifically designed for use in plastic, thread quicker and truer into the valve body. They are compatible with a variety of tools: a hex nut driver, a Phillips screwdriver or slotted screwdriver for easy servicing. When installing irrigation systems, something as simple as a bonnet screw design is all that it takes to save time and money.



Auckland NZ
PH: (09) 919 7600
FAX: (09) 919 7604

Distributed by: **aquaspec**
www.aquaspec.co.nz 0800 353 966

Christchurch NZ
PH: (03) 968 3230
FAX: (03) 968 3231

FEATURES AND BENEFITS

Globe or Angle Models...

Flexibility in design

Many times the irrigation main line is installed much deeper than the system's lateral lines. This may be due to local codes or for freeze protection. For these situations, Hunter offers 1½" and 2" valves with a globe/angle configuration in one valve. The globe configuration offers the best choice for those systems that have the main line at the same depth as the laterals. The angle configuration allows the installer to place the valve on top of a deep main line, which allows easy access to the valve for maintenance.

In addition, the PGV angle configuration boasts a lower pressure loss across the valve compared to a globe style valve, providing a big advantage on systems that may experience low operating pressures.

Body Options...

Maximum choices, minimum effort

Hunter is aware of the many different valve requirements that are prevalent in today's irrigation market. With that in mind, the PGV is designed as a very adaptable valve in the residential/commercial market. The PGV is available with a variety of inlet and outlet sizes and configurations: NPT, BSP, Male x Barb, Male x Male, and Slip.

The barb outlet valves have become an instant hit in the colder regions of the US, where polyethylene pipe is frequently used for laterals. Contractors report their installation times have decreased tremendously when this valve is used on their jobs. Eliminating the addition of an extra adapter or two to the manifold not only saves time and money, but also saves on the possibility of leaks.

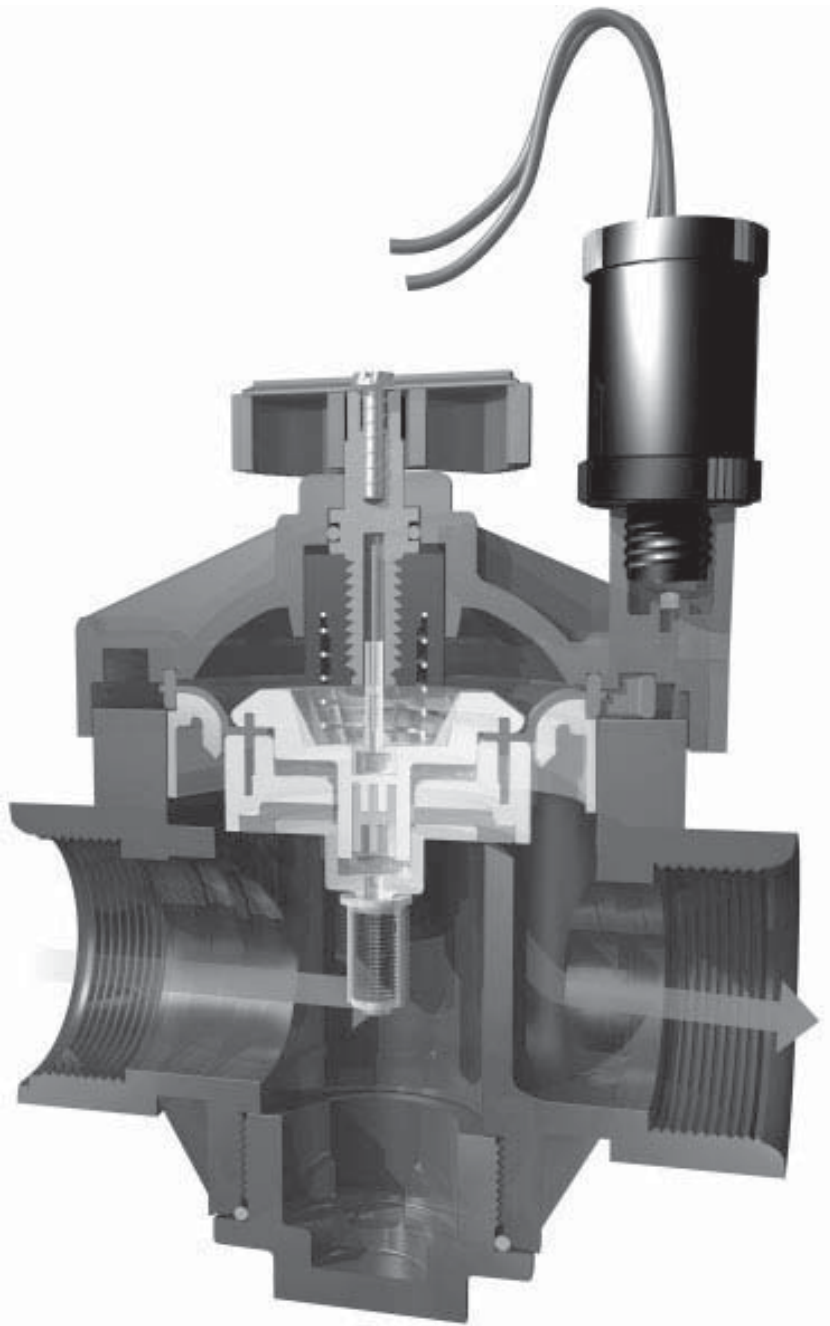

Auckland NZ
PH: (09) 919 7600
FAX: (09) 919 7604

Distributed by: **aquaspec**
www.aquaspec.co.nz 0800 353 966

Christchurch NZ
PH: (03) 968 3230
FAX: (03) 968 3231

The many options available:

1" GLOBE

with FLOW CONTROL

fpt x fpt — NPT, BSP
mpt x mpt — NPT, BSP
mpt x barb — NPT, BSP
slip x slip



1" GLOBE

without FLOW CONTROL

fpt x fpt — NPT, BSP
mpt x mpt — NPT, BSP
mpt x barb — NPT, BSP
slip x slip



Note: The 1" barb is sized for USA poly markets only.

1" ANGLE

with FLOW CONTROL

fpt x fpt — NPT



1" ANGLE

without FLOW CONTROL

fpt x fpt — NPT

1 1/2" GLOBE/ANGLE

with FLOW CONTROL

fpt x fpt — NPT, BSP



2" GLOBE/ANGLE

with FLOW CONTROL

fpt x fpt — NPT, BSP



Barbed Connections...

Poly pipe connections made easy



An overwhelming request by Hunter valve users was to develop a valve with a barb outlet connection built into the valve for poly pipe users. Hunter responded with four 1" models to choose from. The 1" globe with flow control in MNPT and MBSP threads and the 1" globe without flow control in both MNPT and MBSP threads are now available. With all of these models, the time-saving benefits have proven to be substantial for the installer, because they no longer need to thread adapters or nipples wrapped with Teflon tape into the valve to attach to poly pipe systems.

Flow Range...

Highly versatile valve for all flow requirements

The flow range of the PGV is exactly what installers are looking for in 1", 1 1/2", and 2" valves. Systems requiring a flow rate as low as 1 gpm (60 gph), such as for low-volume irrigation, are easily accommodated with the 1" PGV. Also, irrigation systems running up to 120 gpm per zone, which can be found on large commercial sites, are well within the 2" valve's designed capabilities.

High-grade materials used for a 150 psi rating...

Made of durable materials to resist wear

If you are in the market for a valve that needs to take the pressure, the PGV is your choice. Featuring solid heavy-duty construction built with an ABS skirted bonnet, this valve takes up to a constant 150 psi without regard to hot summer temperatures. The superior design of the PGV helps eliminate any reduction in performance when temperatures go up: a common occurrence with 100% PVC constructed valves.

Auckland NZ
PH: (09) 919 7600
FAX: (09) 919 7604

Distributed by: **aquaspec**
www.aquaspec.co.nz 0800 353 966

Christchurch NZ
PH: (03) 968 3230
FAX: (03) 968 3231

Heavy-duty Solenoid...

Provides dependable operation and long life

The entire line of Hunter valves has something in common: the same heavy-duty five-year warranty solenoid. Installers will find that not having to stock two or three different solenoids for valves of the same manufacturer are a real plus. Another plus is the solenoid's captive plunger, which enables easy servicing of the solenoid but eliminates the chance for any lost internal parts.

It only takes 1½ turns to remove or replace the solenoid which makes twisted solenoid wires a non-issue (a tremendous benefit to installers or maintenance people who work with valves).

The Hunter solenoid is unique because it operates on a reverse flow principle. The center hole in the solenoid bowl is an inlet port, instead of an exhaust port. When installing long wire runs, this solenoid is very efficient, especially under high system pressures.

A big advantage to this reverse flow action is that it reduces potential large pressure spikes against the valve. Such spikes could cause damage not only to the valve, but to other components of the irrigation system as well. With the PGV, when a surge pressure spike hits the closed valve, the solenoid plunger will open slightly to allow the spike to travel downstream and dissipate through the zone piping, minimizing any damage that could occur. The solenoid plunger then closes immediately, preventing unscheduled system operation.

Captive Bonnet Screws, Diaphragm and Solenoid Plunger...

No lost parts during servicing

When servicing is required, the PGV is the valve that makes it easy. The screws, captive within the bonnet, are designed to be removed by a nut driver, Phillips, or slotted screwdriver. Another unique characteristic to the PGV line is the type of screw used.

Specifically designed for use in plastic, the screw sports a large thread gain, allowing it to thread quicker and truer into the valve body.

In addition, all parts are captive within the solenoid (a great feature in a valve, assuring those parts will not be lost in the mud). The PGV also features screw through-holes in the valve body for trouble-free screw placement. If dirt gets into these holes it's no problem: as the screw is turned into the body, the dirt comes out the bottom. (It sounds simple, but other brands actually require removal of the valve to clean out the debris.)

Fully Supported Diaphragm...

Prevent stress failure in tough conditions

The PGV diaphragm is fully supported by an ingenious diaphragm support ring designed to prevent premature stress failure. The ring is also designed with small holes in it. These holes allow water to keep the diaphragm from sticking to the support ring after periods of non-use, such as before the landscaping is installed or winter shutdown.



Captive bonnet screws

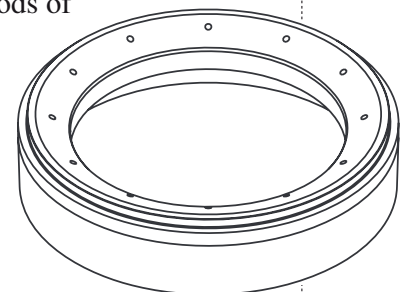

Diaphragm support ring prevents stress failures.

Auckland NZ
PH: (09) 919 7600
FAX: (09) 919 7604

Distributed by: **aquaspec**
www.aquaspec.co.nz 0800 353 966

Christchurch NZ
PH: (03) 968 3230
FAX: (03) 968 3231

Debris Tolerant...

Designed to eliminate failure caused by debris

With the PGV valve installed in the irrigation system, callbacks for weeping valves are a thing of the past. The PGV is highly debris tolerant because of its "crowned" body seat and a revolutionary new polymer that is used in the diaphragm seat assembly. By virtue of the fact that the body seat is crowned it will not allow any contaminants to catch during valve closing,

making it very difficult for debris to become trapped by the diaphragm. If debris were to become imbedded in the diaphragm seat, the polymer material utilized in the diaphragm seat retains its original shape after the imbedded debris is flushed through the valve.

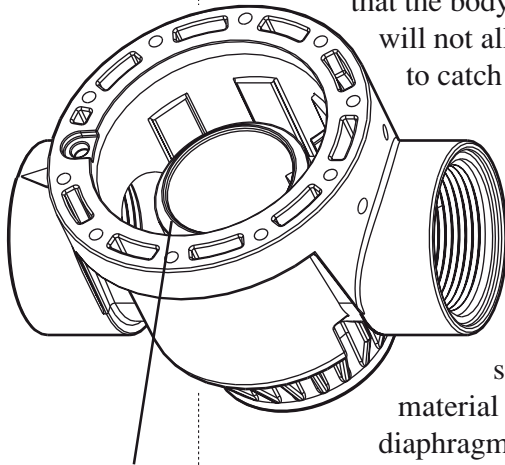

Crowned body seat

Adjustable Flow Control With Non-Rising Handle...

Flow adjustment and servicing made easy

Flow management is a simple process when using the Hunter PGV with its non-rising flow control handle in the 1½" and 2" sizes. A non-rising handle means the valve can be placed closer to the valve box lid for easier servicing.

When fine tuning the system, adjust to the desired zone flow either by hand or using a valve key. If necessary, the easy-to-turn flow control handle completely shuts the valve off without the possibility of damage to the diaphragm, even under maximum pressure and flow conditions.

Non-rising flow control handle

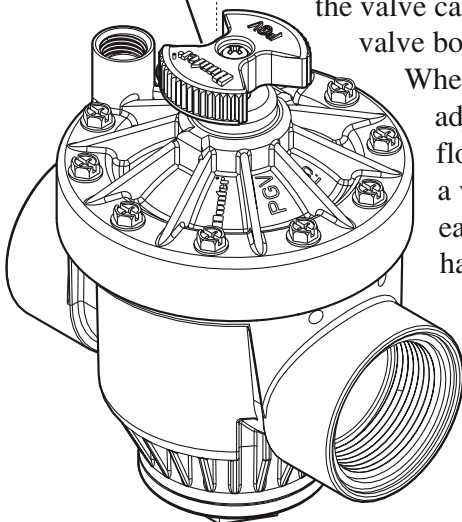

Optional Flow Control in 1" Sizes

Facilitates flow management as needed

The 1" PGV can be ordered with or without an optional flow control stem. With the flow control option, zone water pressure and flow can be managed right at the valve for optimum efficiency. A removable flow control handle, generously sized for easy gripping, makes flow adjustment a quick and easy process.

Heavy-duty Bonnet...

Designed to provide maximum durability

Through repeated testing of valve designs, the PGV has incorporated in it a bonnet that goes beyond the typical plastic valve bonnet. The design features a skirt around the perimeter of the bonnet, which gives it incredible rigidity or "hoop strength." An example of this would be the difference in rigidity between a Styrofoam cup with a lid attached and one without a lid attached. Without a lid, the cup is very malleable, but when a lid is attached the cup walls are strengthened tremendously.

Bonnet Air Relief...

Air release to minimize system stresses

The PGV is designed with a patent pending special air relief feature that facilitates the removal of any air bubble from the top underside of the bonnet. The removal of air facilitates the elimination of water hammer. When the flow control stem is pushed downward, any air trapped in the valve is released. The water pressure will then force the stem back up into place without leaking.

Internal Manual Bleed...

Completely dry manual operation

For fast manual operation, a quick ½ turn of the solenoid allows water to bleed off of the top of the diaphragm and, as a result, opens the valve. All the water goes through the valve, which means no more water continuously leaking into valve boxes.

Auckland NZ
PH: (09) 919 7600
FAX: (09) 919 7604

Distributed
by: **aquaspec**
www.aquaspec.co.nz

Christchurch NZ
PH: (03) 968 3230
FAX: (03) 968 3231
0800 353 966

Accu-Set™ Dial Control Pressure Regulation...

For use on 1" without flow control, 1½", and 2" valves

Exact pressure settings are a certainty every time with Hunter's Accu-Set™ pressure regulating module with its easy-to-read dial settings. This dial assures exact downstream pressure between 20 and 100 psi (1.4 to 7.0 bars, 138 to 689 kPa). There are no extra gauges to carry for pressure adjustments or inspection. (A schraeder valve is included on the unit for job specifications requiring checking and setting using a gauge only.)

The Accu-Set™ dial-in module provides an accurate working (or dynamic) pressure to the zone. The module constantly adjusts as needed to provide a consistent outlet pressure regardless of inlet pressure variations.

The Accu-Set™ pressure regulator is an important tool a professional installer will use when the irrigation main lines need to be at maximum pressures due to long pipe runs or when static supply pressures are too high for sprinkler operation. Also, the Accu-Set™ is the product of choice when different zones require different outlet pressures due to product specifications, such as large rotor sprinklers zoned off the same main line as sprayheads.

The benefit of the Accu-Set™ is that the irrigation system does not need to be pressurized to adjust it, resulting in a very fast installation. With this unique pressure regulating module, just set the easy-to-read dial to the desired pressure, with or without the system operating. The pressure dialed in is the pressure delivered to the zone.

The optional Accu-Set™ pressure regulating module is easy to retrofit on all ICV valves, as well as 1" without flow control, 1½" and 2" field installed PGV valves. On systems determined to have high-pressure problems after installation, the amount of time saved in labor, along with reduced costs, is considerable. That's because the Accu-Set™ is installed without

a hassle, without cutting pipe and without replacing valves.

Accu-Set™ Installation Instructions

1. Remove the solenoid from the Hunter PGV irrigation valve. (The 1" valve with flow control is not designed for use with the Accu-Set™.)

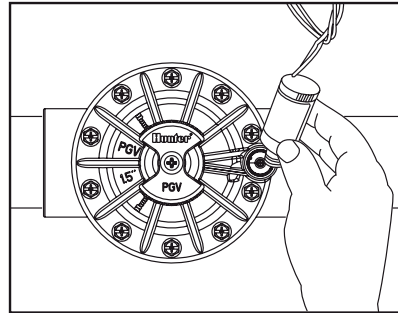

2. Thread the Accu-Set™ into the solenoid area of the PGV.

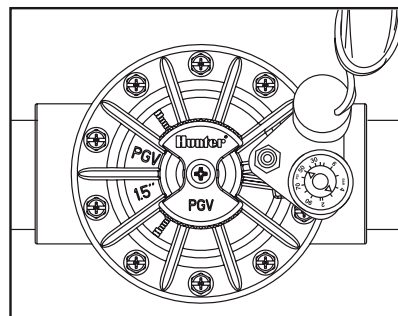

3. Thread the solenoid into the Accu-Set™.

Accu-Set™ Pressure Regulator Adjustment

1. Turn the clear dial on the top of the Accu-Set™ until the arrow underneath the clear dial is pointing to the desired downstream pressure.
2. The white colored scale is for PSI, the yellow colored scale is for BAR.

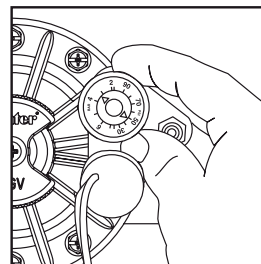

Auckland NZ
PH: (09) 919 7600
FAX: (09) 919 7604

Distributed
by: **aquaspec**
www.aquaspec.co.nz

0800 353 966

Christchurch NZ
PH: (03) 968 3230
FAX: (03) 968 3231

PRODUCT COMPARISONS

FEATURES	Hunter PGV	Rainbird PGA	Irritrol 200B	Toro 252	Nelson 7900	Weathermatic 21000
150 PSI Rated Operating Pressure	✓	✓	✓	✓	✓	✓
Models to Accommodate Globe/Angle Configuration	✓	✓	✓	✓	✓	
Flow Control with Non-Rising Handle	✓	✓				✓
Internal Manual Bleed	✓	✓	✓		✓	✓
Bonnet Air Relief	✓		✓	✓	✓	
Captive Diaphragm	✓				1" model	
Captive Bonnet Screws	✓		✓		1" model	
Triple Tool Stainless Steel Bonnet Screws	✓		✓		1" model	
Easy Bonnet Removal (4 Screws on 1" Valve)	✓				✓	
Less Than 1 1/2 Turns to Remove Solenoid	✓					
Reverse-Flow Solenoid Design to Reduce Line Surges	✓					
Interchangeable Solenoid with All Plastic Valves in Catalog	✓		✓		✓	
Female Inlet/Outlet NPT / BSP Option	✓	✓	✓	✓	✓	✓
Male Inlet/Outlet MPT / Barb Option	✓					
1" Valve Inlet/Outlet Solvent-Weld Slip Option	✓					
Vent Holes in Diaphragm Support	✓					
Dial to Setting Pressure Regulator Option without extraneous tubing	✓		✓			
Less Than 2.5 PSI Loss at 25 GPM in 1" Valve	✓					
Less Than 3.1 PSI Loss at 100 GPM in 2" Valve	✓			✓		
Optional Conduit Cover	✓	✓	✓		✓	

PRODUCT EXPLANATION

EXAMPLE: **PGV - 100G - S - AS**

MODELS

PGV-100G = 1", Globe Valve, no Flow Control
 PGV-101G = 1", Globe Valve, with Flow Control
 PGV-100A = 1", Angle Valve, no Flow Control
 PGV-101A = 1", Angle Valve, with Flow Control
 PGV-100MM = 1", Globe Valve, no Flow Control, male threads
 PGV-101MM = 1", Globe Valve, with Flow Control, male threads
 PGV-100MB = 1", Globe Valve, no Flow Control, male thread x barb
 PGV-100MB = 1", Globe Valve, with Flow Control, male thread x barb
 PGV-151 = 1 1/2", Globe/Angle Valve, with Flow Control
 PGV-201 = 2", Globe/Angle Valve, with Flow Control

OPTIONS

S = Slip x Slip
 (1" models only)
 B = BSP Threads

OPTIONS USER INSTALLED

AS = Accu-Set™ Pressure Regulator
 (1" without Flow Control, 1 1/2" and
 2" models only)
 R = Reclaimed Water Identification
 Handle

Auckland NZ
 PH: (09) 919 7600
 FAX: (09) 919 7604

Distributed
 by: **aquaspec**
 www.aquaspec.co.nz 0800 353 966

Christchurch NZ
 PH: (03) 968 3230
 FAX: (03) 968 3231

TECHNICAL INFORMATION

MODELS

PGV-100G – 1" plastic globe valve

PGV-101G – 1" plastic globe valve with flow control

PGV-100A – 1" plastic angle valve

PGV-101A – 1" plastic angle valve with flow control

PGV-100MM – 1" plastic globe valve, male x male threads

PGV-101MM – 1" plastic globe valve with flow control, male x male threads

PGV-100MB – 1" plastic globe valve, male thread x barb

PGV-101MB – 1" plastic globe valve with flow control, male thread x barb

PGV-151 – 1 1/2" plastic globe/angle valve with flow control

PGV-201 – 2" plastic globe/angle valve with flow control

DIMENSIONS

- 1" Globe – 5" H (13 cm) x 4 1/2" L (11 cm) x 2 1/2" W (6 cm)
- 1" Angle – 5 1/2" H (14 cm) x 3 1/2" L (9 cm) x 2 3/4" W (7 cm)
- 1 1/2" Globe/Angle – 7 1/2" H (19.1 cm) x 5 3/4" L (14.6 cm) x 4 1/2" W (10.8 cm)
- 2" Globe/Angle – 8" H (20.3 cm) x 6 3/4" L (17.1 cm) x 5 1/4" W (13.3 cm)

OPERATING SPECIFICATIONS

- Flow: 1 to 120 gpm (0.23 to 27.2 m³/hr; 3.8 to 454.2 l/min)
- Pressure: 20 to 150 psi (1.4 to 10.3 bars; 138 to 1034 kPa)
- Heavy-duty solenoid: 24VAC, 50/60 cycles, 400mA inrush current, 270mA holding current
- BSP Models: 24VAC, 50 cycle solenoid, 280mA inrush current, 190mA holding current

OPTIONS AVAILABLE

- Accu-Set™ pressure regulator
- Reclaimed water identification handle

Pressure Loss in PSI		
GPM	1" Valve	
	Globe	Angle
1	1.1	1
5	1.9	1
10	1.9	1
15	1.6	1
20	3.3	2
30	6.1	3

Pressure Loss in PSI				
GPM	1 1/2"		2"	
	Globe	Angle	Globe	Angle
20	3	3	1	1
30	3	3	1	2
40	3	3	2	2
50	4	3.5	1	1
60	5	4	2	2
80	5.5	4.5	3	2
100			5	3
120			6	5

Pressure Loss in Bars		
m ³ /hr.	1" Valve	
	Globe	Angle
0.23	0.08	0.07
1.14	0.13	0.07
2.27	0.13	0.07
3.41	0.11	0.07
4.54	0.23	0.14
6.81	0.42	0.21

Pressure Loss in Bars				
m ³ /hr.	1 1/2"		2"	
	Globe	Angle	Globe	Angle
4.54	0.21	0.21	0.07	0.07
6.81	0.21	0.21	0.07	0.14
9.08	0.21	0.21	0.14	0.14
11.36	0.28	0.24	0.07	0.07
13.63	0.34	0.28	0.14	0.14
18.17	0.38	0.31	0.21	0.14
22.71			0.34	0.21
27.25			0.41	0.34

Pressure Loss in kPa		
l/min	1" Valve	
	Globe	Angle
3.8	7.58	6.89
18.9	13.10	6.89
37.9	13.10	6.89
56.8	11.03	6.89
75.7	22.75	13.79
113.5	42.06	20.68

Pressure Loss in kPa				
l/min	1 1/2"		2"	
	Globe	Angle	Globe	Angle
75.7	20.7	20.7	6.9	6.9
113.6	20.7	20.7	6.9	13.8
151.4	20.7	20.7	13.8	13.8
189.3	27.6	24.1	6.9	6.9
227.1	34.5	27.6	13.8	13.8
302.8	37.9	31.0	20.7	13.8
378.5			34.5	20.7
454.2			41.4	34.5

Charts based on full-open flow control position.

Auckland NZ
PH: (09) 919 7600
FAX: (09) 919 7604

Distributed by: **aquaspec**
www.aquaspec.co.nz 0800 353 966

Christchurch NZ
PH: (03) 968 3230
FAX: (03) 968 3231

INSTALLATION DETAILS

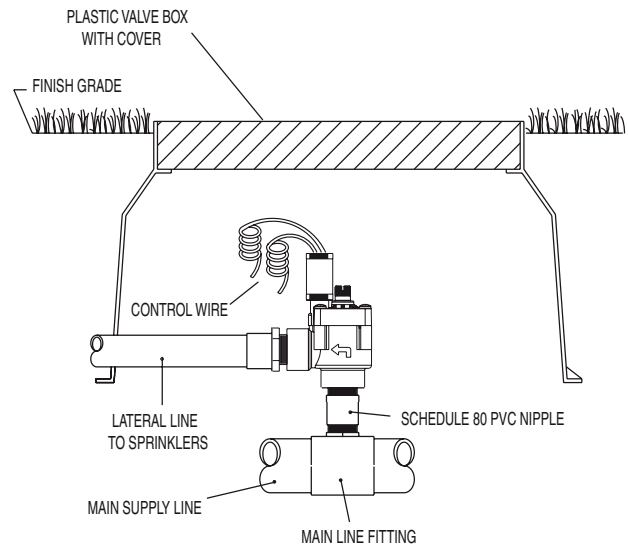
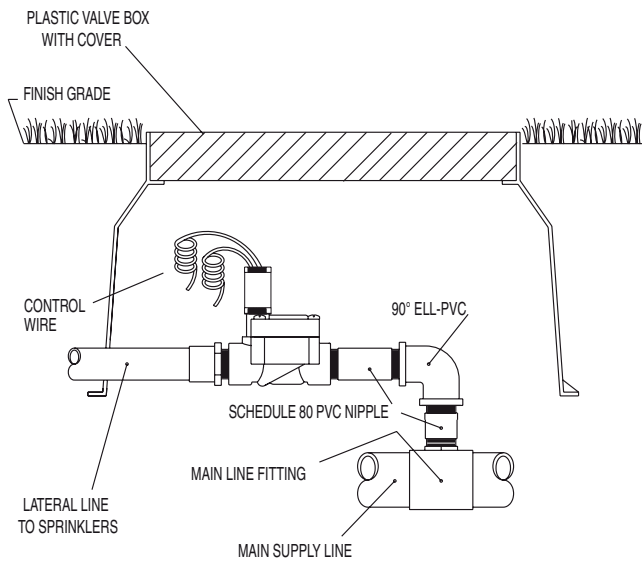

Hunter® 1" PGV-GLOBE

Hunter® 1" PGV-ANGLE

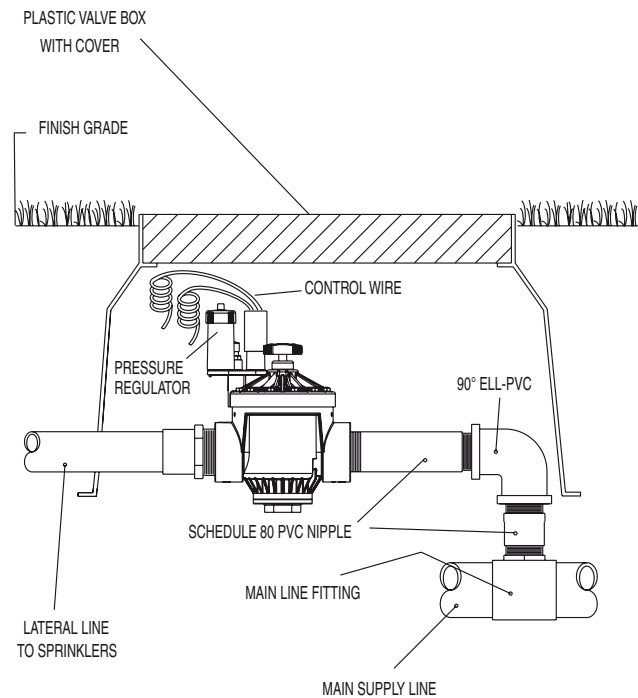
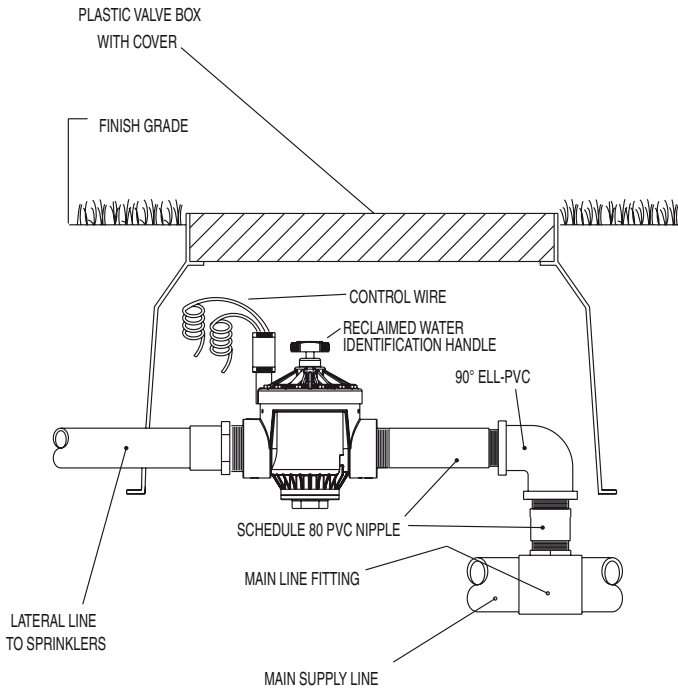

Hunter® 2" PGV-NP

Hunter® 2" PGVW/PR

Auckland NZ
 PH: (09) 919 7600
 FAX: (09) 919 7604

Distributed by: **aquaspec**
www.aquaspec.co.nz 0800 353 966

Christchurch NZ
 PH: (03) 968 3230
 FAX: (03) 968 3231

VALVE OPERATION

Basic Principles of Valve Operation

Water enters the valve from the system main line and exerts a force against the center of the valve's diaphragm. A small orifice in the diaphragm allows the water to flow through to the upper chamber between the diaphragm and the bonnet. The water continues to travel on through a port in the bonnet to the solenoid area. The solenoid has a light spring loaded metal piston that, when the valve is closed, covers the inlet port hole. The surface area that the water comes in contact with on top of the diaphragm is greater than the surface area on the bottom of the diaphragm, so the valve stays closed until the water in the upper chamber is released. (pressure x area = force)

Electrically Opening a Valve

When the solenoid coil is electrically charged, the current creates an electromagnetic field and pulls the piston off of the port hole seat allowing water to flow into the solenoid chamber, out of the solenoid exhaust port, and into the downstream pipe. The solenoid ports are larger than the orifice in the diaphragm, so the water flows out of the upper diaphragm/bonnet chamber faster than it is allowed to enter. The pressure on the top of the diaphragm is released through these ports, and the force from the mainline side pushes against the diaphragm and causes the valve to open.

Manually Opening a Valve

The same principle is at work when a valve is manually opened using the manual bleed. The pressure on the top of the diaphragm is released through the use of an internal or external bleed. The internal bleed on the ICV mechanically lifts the solenoid piston off of the upper chamber exhaust port allowing the water to be released into the downstream pipe. Some valves have an external bleed which allows water to exit the upper diaphragm chamber into the valve box.

Closing a Valve

When the controller turns off the low voltage current flow, the solenoid spring pushes the piston back over the inlet port, and stops the flow of water from going through the solenoid chamber and exhaust port. The upper diaphragm/bonnet chamber begins to fill, and soon reaches an equilibrium point when the psi (pounds per square inch) is the same on both sides of the diaphragm. The diaphragm spring continues to gently push on the diaphragm, closing the valve further. The combination of the spring exerting pressure on the diaphragm and the water building up in the upper chamber bring the valve to a closed position.

PGV REPLACEMENT PARTS

PGV-100G/101G

Item	Description	Part No.
①	Solenoid Assembly <i>(Includes Parts 2 & 3)</i>	380500
②	O-Ring	262600
③	Solenoid Seal	364400
④	Bonnet Screw	424200
⑤	Bonnet with Flow Control	379405
	Bonnet without Flow Control	331105
⑥	Diaphragm Spring	266000
⑦	Diaphragm Assembly	332100
⑧	Diaphragm Support Ring	331300
⑨	Body	
	Globe, NPT Thread	331020
	Globe, BSP Thread	331025
	Globe, Slip	331030
	Globe, Male X Male, NPT Thread	433400
	Globe, Male X Male, BSP Thread	433405
	Globe, Male X Barb, NPT Thread	460700
	Globe, Male X Barb, BSP Thread	460705
⑩	Flow Control Handle	269200

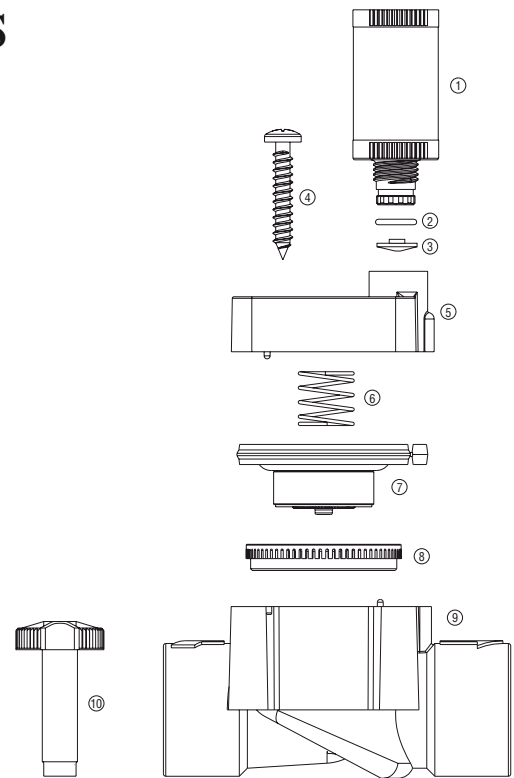

PGV-100A/101A

Item	Description	Part No.
①	Solenoid Assembly <i>(Includes Parts 2 & 3)</i>	380500
②	O-Ring	262600
③	Solenoid Seal	364400
④	Bonnet Screw	424200
⑤	Bonnet with Flow Control	379405
	Bonnet without Flow Control	331105
⑥	Diaphragm Spring	266000
⑦	Diaphragm Assembly	332100
⑧	Diaphragm Support Ring	331300
⑨	Body	407000
⑩	Flow Control Handle	269200

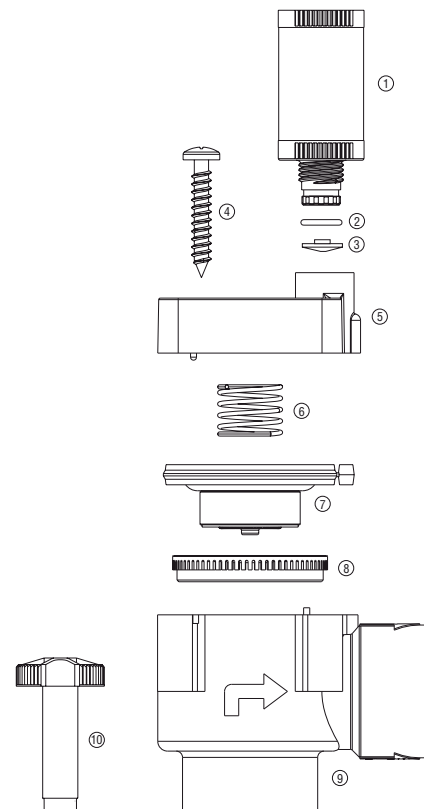

PGV REPLACEMENT PARTS

PGV-151G/201G

Item	Description	Part No.	
①	Solenoid Assembly (Includes Parts 2 & 3)	380500	
②	O-Ring	262600	
③	Solenoid Seal	364400	
④	Flow Control Handle Screw	334000	
⑤	Flow Control Handle	412700	
⑥	Bonnet Screw	331105	
⑦	Bonnet	1 1/2"	414000
		2"	415500
⑧	Flow Control Stem	1 1/2"	421500
		2"	414600
⑨	Spring	1 1/2"	412300
		2"	414200
⑩	Diaphragm Assembly	1 1/2"	414100
		2"	415600
⑪	Diaphragm Support	1 1/2"	413100
		2"	414800
⑫	Body	1 1/2" NPT	412400
		1 1/2" BSP	412405
		2" NPT	414300
		2" BSP	414305
⑬	Body Plug without O-Ring	1 1/2" NPT	419200
		1 1/2" BSP	419205
		2" NPT	419300
		2" BSP	419305
⑭	Plug O-Ring	1 1/2"	413900
		2"	415400

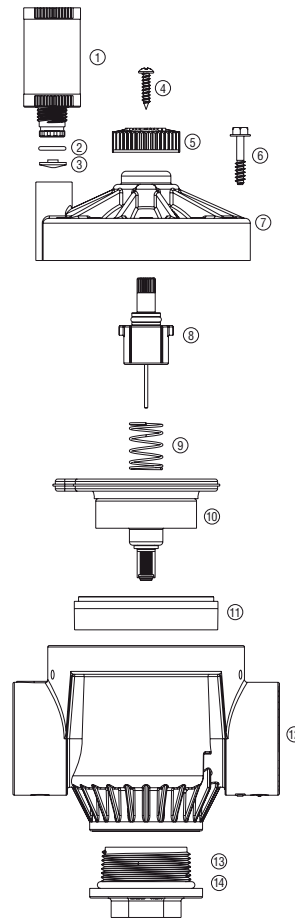

Accu-Set™

Item	Description	Part No.
①	Adjustment Knob	368500
②	O-Ring	262600
③	Inlet Seal	368200

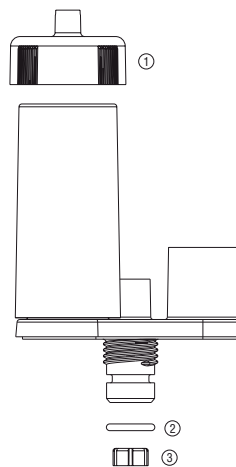

Auckland NZ
PH: (09) 919 7600
FAX: (09) 919 7604

Distributed by: **aquaspec**
www.aquaspec.co.nz 0800 353 966

Christchurch NZ
PH: (03) 968 3230
FAX: (03) 968 3231